

DEVELOPMENT OF LEAKAGE CONTROLLED FLOW DIVERSION SAFETY VALVES

E. FORGÁCS, J. CSANÁDI, C. HODÚR, G. SZABÓ

UNIVERSITY OF SZEGED,
FACULTY OF FOOD ENGINEERING

ABSTRACT

The strict instructions for heat-treating of raw milk are contained in Codex Alimentarius Hungaricus, 92/46, 92/380 EU Directives and 1/2003 (I.08) FVM-ESzCsM decree. Most of the applied equipments for heat-treating of raw milk have no flow direction valve, which should guarantee the heat-treating of milk by directives in all cases.

The goal of the project: to develop a safety flow-diversion valve for small and medium dairy firms in order these firms will be able to satisfy the EU directions, in this way, their products can take part in the Eu dairy market as well

Developed flow-diversion valve fitted small pipe diameter has double valve seat and leakage system.

The main advantage of developed valve is the follows: the raw milk or failure heat-treated milk doesn't able to flow into the regenerative sections of equipment in the case of the failure of gaskets, even more it shows the gasket failure with leakage.

Using equipments with developed valve cancel a main critical point from the Quality Management System. Innovated valve is quickly installable with standard binder items.

The flow-diversion safety valve, which was developed by Zootechnika Ltd. and University of Szeged, sponsored by EU and Hungarian National Program GVOP 3.1.1-2004-05-0275/3.0. has a Qualification from Bundesanstalt für Milchforschung Institution Kiel n:KI-S 5/04.

1. INTRODUCTION

Our joining the EU on 1st May 2004 means possibilities and challenges as well as the so-called globalization. Simultaneously we have to note reluctantly that the legal and official prescriptions and regulations may become inconsiderate tools of market competitions sometimes. Naturally these are destined for the protection of customers, but unready producers as market persons can be affected like a bolt from the blue by the demands of prescriptions or regulations indicated perhaps by competitors

on the market - as some precedents have happened so far. However, such products can be found on the market of the Union after some years of tolerance, which suit in every respect the very severe conditions created in connection of the production and marketing of foods.

For home milk processing plants such a new challenge is to ensure warranted safe heat treatment of raw milk in such a manner which excludes any kind of possible forms of after-infection. In addition suitability of applied procedure must be verified. The achievement of this is not realizable in most home creamery without technical development, innovation and investment.

2. PRECEDENTS

Judiciary background

New sanitary prescriptions related production and marketing of raw and heat- treated milk as well as milk products were established in the **Communiqué of the Council of European Communities** (Directive 92/46, 1992).

The Appendix B and chapter V of this directive deals *with the special requirements for licensing of heat- treating and processing institutions* and describes that:

"... heat treating and processing institutions must possess at least:

- (f) a heat treating equipment approved or permitted by authorities responsible, which is equipped with:

- temperature controller,

- recording thermometer,

- automatic safety device, which prevent the insufficient heating,

- suitable safety system, which prevents mixing of pasteurized or sterilized milk and milk heated insufficiently,

- automatic data recorder to the safety system mentioned in the preceding item

..."

For instance, pneumatic reversing valves built-in behind holding section of pasteurizer are destined for the fulfillment of above recommendation. According to experiences of hygienic controls, valves of such function are absent in the system in several places. If there are some, this does not satisfy demands on exclusion of all possibilities for reinfection, or they are cut out. But such valves have not existed so far for small-scale devices and for small tube diameters.

Effect of operation of the diversion valve on pasteurization

The task of reversing valve is to secure the stream of milk in alternative bifurcating directions from heating or holding sections of the pasteurizer. The aim of this operation is to prevent the flow of milk of inadequate quality in return tract of the pasteurizer where thermal energy of hot milk is used for preheating the incoming cold milk. Because an

intensive heat exchange also takes place in this tract, hot milk quickly cools to such temperature that system-infecting microbes can cause spoilage by getting into the milk destined for packing or following use.

Valves are usually controlled with automation using signals of temperature sensor and their automatic change occurs by remote control. Most of all operation of such valves is worked out by means of compressed air.

Critical conditions of valve operation:

- Accuracy of temperature signal coming in the controller,
- Accuracy and reliability of control program in the built-in system,
- Adequacy and authenticity of operating air and/or mechanic elements,
- Suitable flow conditions inside the valve.

In the best, case reversing valve is used during heating up of the system, at the end of pasteurization and by washing, respectively. Its operation is inevitable in these steps of production to prevent after-infections or mixing of the milk with other materials (e.g. washing solutions).

After-infection is the most dangerous problem during heating up of the system, because milk does not achieve its required germicidal effect yet, so return tracts can be considerably infected. Infection can be resulted, when some kinds of defects arise in the operation or tightness of the valve. A continuous leaking is frequent resulting from packing defects in the case of valves without leakage control. This is the most dangerous defect, because it is hidden and both outputs of the system are infected. Very significant germ propagation can occur in the stagnant milk in the tract out of use, which may threaten other systems later. Infection of the return line of the milk is the most dangerous problem during heating up, because in this case infection occurs under slow flow velocity. There are such tracts in the pasteurize where stagnant and slowly escaping milk may cause deposits, which can be removed by subsequent high flow velocity only after longer time.

Automatic reversal of suitable heat-treated milk into the return tract will sooner or later wash away the infective flora from the system. In fact infection will be diluted so much that it will not cause further trouble Milk of expected good quality will continuously be infected by centers originating from heating until required dilution is produced Milk quantity necessary for dilution is very difficult to be estimated, therefore solution can be attained only by application of leakage controlled valves. Their application excludes infection of returning milk. Packing defect is indicated simultaneously by milk leaking from the valve in a distinctly visible. So defect can be removed quickly and safe pasteurization can be continued.

Unfortunately leakage controlled valves are used typically in pasteurizers of high-efficiency, such valves are rarely found in machines of low- and medium-efficiency.

We have developed leakage controlled flow diversion safety valves (**LFDV**) with double valve seat presented below, to satisfy above requirements in pasteurizers of low-efficiency.

3. RESULTS AND DISCUSSION

Powers and pressures necessary for perfect closing of valve disks and seats in valve constructed were determined on the basis of registered data in the first step. In starting position valve disk and seat (1, 2) are closed, pressure necessary for closing is provided by spring force. There are two springs (R_1 , R_2) in the valve. In starting position spring R_2 keeps the valve closed, while spring R_1 works against it. Spring forces were determined from tables:

$$R_1 \rightarrow D=16[\text{mm}], d=2[\text{mm}], L_0=52$$

$$\mathbf{F_1=198 [N]}$$

$$R_2 \rightarrow D=34[\text{mm}], d=4[\text{mm}], L_0=54$$

$$\mathbf{F_2=523 [N]}$$

Determination of acting pressure on closing surface A1 (ring "O"):

$$A_1 = \frac{(D_2 - D_1)^2 \pi}{4} = \frac{(40\text{mm} - 39\text{mm})^2 \pi}{4} = 0.78\text{mm}^2$$

Pressure:

$$P_1 = \frac{F_2 - F_1}{A_1} = \frac{523 - 198}{0.78\text{mm}^2} = 416\text{kPa} \cong 4.16\text{bar}$$

Determination of velocities

$$\text{Flow cross section: } A = \frac{d^2 \pi}{4} [\text{m}^2]$$

$$d = 20 [\text{mm}] = 0,02 [\text{m}] \rightarrow$$

$$A = \frac{0,02^2 \pi}{4} = 0,000314 [\text{m}^2]$$

Liquid flow (from instrument reading):

$$Q = A \times v [\text{dm}^3/\text{h}.$$

$$\text{Velocity: } v = \frac{Q}{A \times 1000 \times 3600} \left[\frac{\text{m}}{\text{s}} \right]$$

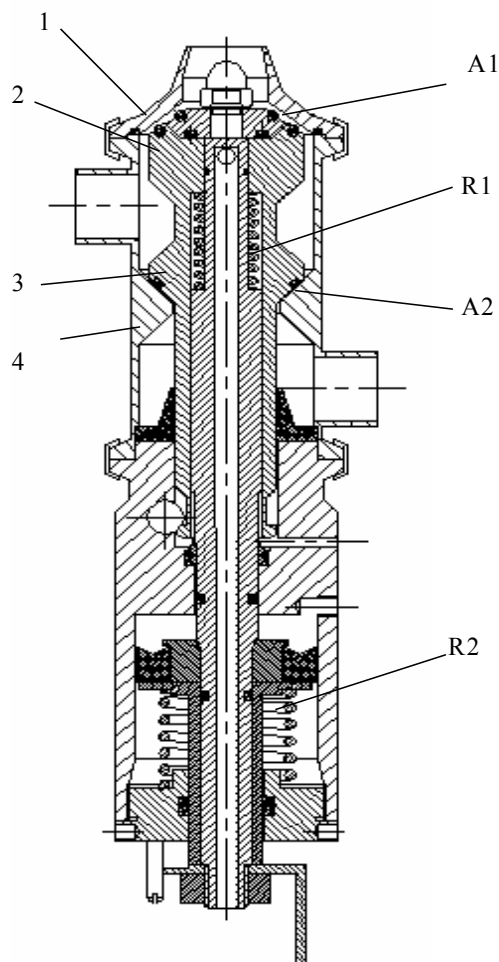

FIGURE 1. THE CUTAWAY VIEW OF VALVE

After change the valve is closed at the bottom, an air pressure of 6 bars adds to spring force, so a force R_1 + force originating from air pressure works against R_2 . (Figure 1.)

Pressures and liquid velocities in the valve were modeled with computer program. Velocity values evolving in LFDV is plotted in the left-hand figure. Liquid pressure values are illustrated in the right-hand side and in the middle figures, respectively.

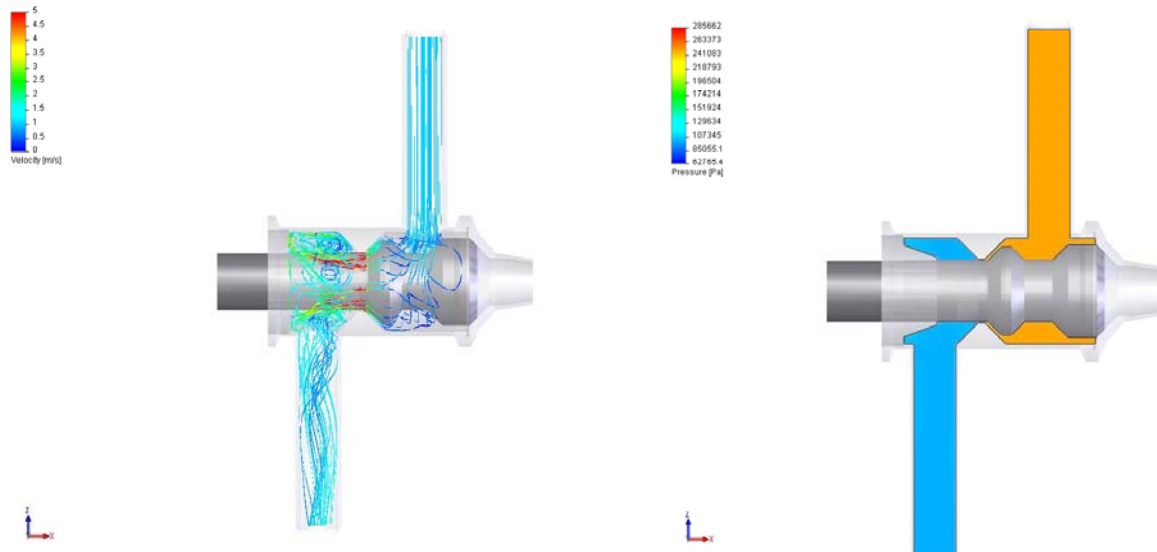

FIGURE 2. CHANGING OF THE FLOW VELOCITY AND PRESSURE IN THE VALVE

Diagram of differences between input and output liquid pressures can be seen on the 3rd Figure.

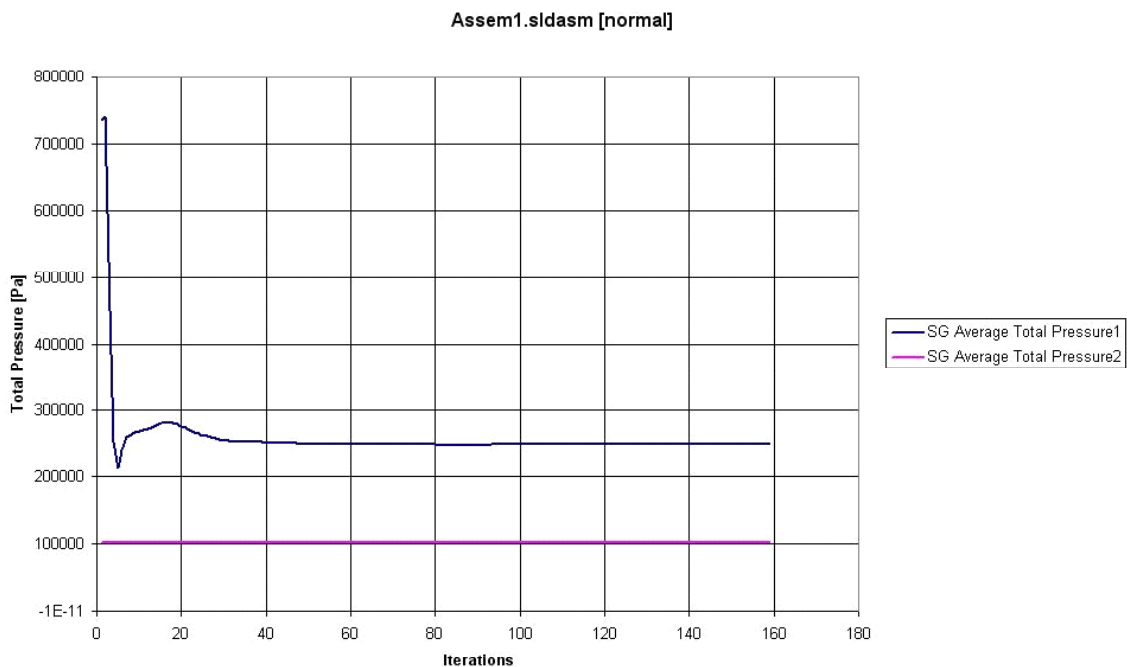

FIGURE 3. DIFFERENCE OF LIQUID PRESSURE AT THE INLET AND OUTLET OF VALVE

Projected valve on the basis of calculations and modeling was found as required.

After production of the valve we had to perform actual tests, from which it could turn out whether the LFDV worked according to prescriptions and projecting.

4. TEST MEASUREMENTS 1

Detailed measuring results are not presented here because of extent limits.

Evaluation of tests

Measurements were performed at liquid temperature of 15°C (in the present case water was used as liquid), at revolution of 2950 min⁻¹ and at gradually increased pressures.

At higher working pressures leakages occurred during tests. The valve did not close perfectly and liquid appeared in both discharge holes, since tract were opened into each other. This defect could be developed because of low force of spring R2. In addition other leakage problems aroused, too.

Cause of defect

- Problem of imperfect closing originated from spring force in the cylinder, which was insufficient to switch the valve completely at higher liquid pressure, the two liquid tracks were only opened into each other.
- Contact surfaces between valve disk and seat were formed at an inappropriate angle. As a result, rings "O" were damaged and leakage defects appeared.
- Double valve seat was dislocated because of its insufficient guidance, which caused further leakage problems.

Elimination of defect

- One extra boring M was fabricated in the cylinder. Its inner sizes were transformed for solving the two-way air input and with that spring force could be helped pneumatically. So working cylinder of double operation was practically applied instead of a cylinder with single

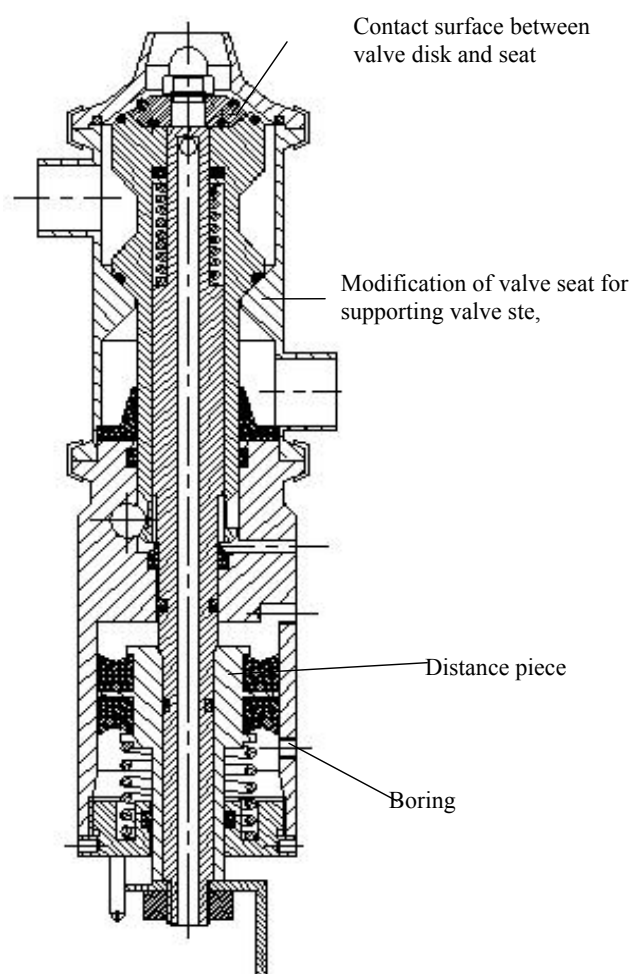

FIGURE 4. THE CUTAWAY VIEW OF THE MODIFIED VALVE

operation, working pneumatically with spring operation. Because of cylinder alteration its head had to be modified, too. Distance pieces in the cylinder had to be substituted with one on which two O rings could be mounted (double packing) for producing pneumatic guidance back and forth.

- Angles of contact surfaces between valve disk and seats were also for more stable bearing and packing.
- Valve seats in valve case were transformed so that they could guide the double valve disk.

Assembly drawing of modified valve is presented in the following figure.

5. TEST MEASUREMENTS 2

Elimination of defect

- A slot for a slip ring had to be formed in the cylinder to eliminate metallic contact between double valve disk and cylinder surfaces.
- Modification of angles of contact surfaces between valve disk and valve seats was continued for even more stable bearing and packing.
- Lower pipe junction on the valve case had to be located 1-2 mm deeper, so liquid could completely leave the valve. Slots for ring "O" had to be formed radial, by its means rings "O" would be seated more precise into the slot ensuring better packing and preventing impurities from penetrating under the ring.

6. TEST MEASUREMENTS 3

New measurements were performed at 15, 75 and 90°C liquid temperatures and at 2950 min⁻¹ pump revolution after elimination of defects. The performed modifications enabled the development of a valve operating satisfactorily on the basis of measurements.

7. CONCLUSIONS

EU directive regarding to safe heat-treating of milk demands building such machine parts in present pasteurizes which can guarantee food safety excluding the after-infection. Provisionally such safety valves are available only in constructions produced for equipments of high-efficiency and for great tube diameters. Operation of reversing valve prepared according to our plans was investigated in a test equipment.

Measurements were performed in several series in the test equipment projected and built for this purpose. Liquid pressure was gradually increased at constant pump revolution of 2950 min⁻¹ and at 15, 75 and 90 °C temperatures. At the bench valve operating factory-like was modeled with several repetitions and alternations of valve position.

Liquid flow was developed with pump in the pipe line of 20 mm diameter in test measurements. Liquid streamed from the tank through volume flow meter to LFDV then back to the tank. Pressure, temperature

and liquid flow was continuously measured. Measuring results were recorded with recorder for subsequent detailed analysis and evaluation.

On the basis of measurements performed after defect corrections and valve modifications it can be established that operation of LFDV meets the expectations. Pressure of the liquid streaming in it does not fluctuate and its velocity remains within prescribed values. The valve changes quickly, perfectly and in a leak-proof way. It is verified with EU qualification KI-S 5/04 by Bundesanstalt für Milchforschung in Kiel, which is at our disposal.

On the basis of our results the project realized with the aid obtained in the scope of European Project is deemed to be successful. The developed safety valve is recommended to home and foreign small-scale plants for purchase and installation.

ACKNOWLEDGEMENT

This work was supported by EU and Hungarian government Project number: GVOP3.1.1. 2004-05-0275/3.0

REFERENCES

- [1.] AMBRUS, V. 1987: Tejipari gépek. Mezőgazdasági kiadó, Budapest
- [2.] BALATONI, M., KETTING, F.: Tejipari kézikönyv. Mezőgazdasági kiadó, Budapest 1981.
- [3.] BARDACH S. (1992): Tejipari szakgéptan. KÉE egyetemi jegyzet, Budapest
- [4.] FENYVESSY J., CSANÁDI J. (1998): Tejipari technológia. JATE SZÉF jegyzet, Szeged
- [5.] 92/46/ EGK Irányelv (1992): A nyerstej, a hőkezelt tej és a tejalapú termékek gyártásával és forgalomba hozatalával kapcsolatos egészségügyi előírások megállapításáról. Európai Közösségek Hivatalos lapja, 1992. június 16, Bruxelles