

THE THERMICAL REGIME IN THE CONTINUOUS CASTING PROCESS – IN MATHEMATICAL INTERPRETATIONS

POPA Erika Monika, KISS Imre, DANCIU Adrian

UNIVERSITY POLITEHNICA TIMIȘOARA,
FACULTY OF ENGINEERING HUNEDOARA

ABSTRACT

Continuous casting is one of the prominent methods of production of casts. Effective design and operation of continuous casting machines needs complete analysis of the continuous casting process. In this paper the basic principles of continuous casting and its heat transfer analysis using the finite element method are presented. In the analysis phase change is assumed to take place at constant temperature. A front tracking algorithm has been developed to predict the position of the solidification front at each step. Finally, examples that are solved by the proposed algorithm are discussed. The results show that there is a good agreement between the method developed in this work and other previously reported works.

1. THE PROCESS – GENERAL NOTES

Continuous casting is the process whereby molten metal is solidified into a "semifinished" billet, bloom, slab or beam blank. Prior to the introduction of continuous casting in the 1950s, steel was poured into stationary moulds to form "ingots". Since then, "continuous casting" has evolved to achieve improved yield, quality, productivity and cost efficiency. Nowadays, continuous casting is the predominant way by which steel is produced in the world.

In the continuous casting process, illustrated in Figure 1, molten metal is poured from the ladle into the tundish and then through a submerged entry nozzle into a mould cavity. The mould is water-cooled so that enough heat is extracted to solidify a shell of sufficient thickness. The shell is withdrawn from the bottom of the mould at a "casting speed" that matches the inflow of metal, so that the process ideally operates at steady state. Below the mould, water is sprayed to further extract heat from the strand surface, and the strand eventually becomes fully solid when it reaches the "metallurgical length".

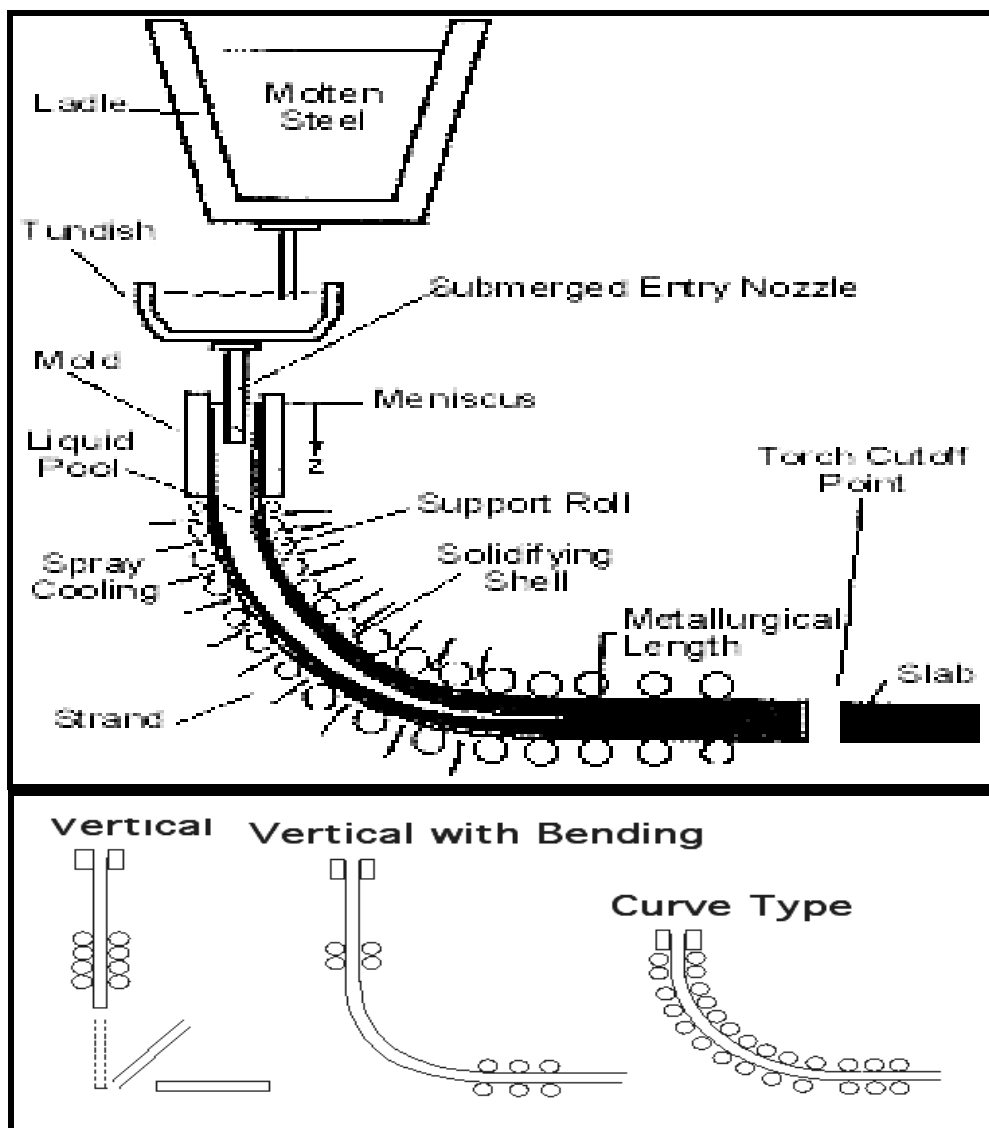

FIGURE 1. SCHEMATIC REPRESENTATION OF THE CONTINUOUS CASTING PROCESS

Solidification begins in the mould, and continues through the different zones of cooling while the strand is continuously withdrawn at the casting speed. Finally, the solidified strand is straightened, cut, and then discharged for intermediate storage or hot charged for finished rolling.

To start a cast, the bottom of the mould is sealed by a steel dummy bar. This bar prevents liquid metal from flowing out of the mould and the solidifying shell until a fully solidified strand section is obtained. The liquid poured into the mould is partially solidified in the mould, producing a strand with a solid outer shell and a liquid core.

In this primary cooling area, once the steel shell has a sufficient thickness, the partially solidified strand will be withdrawn out of the mould along with the dummy bar at the casting speed. Liquid metal continues to pour into the mould to replenish the withdrawn metal at an equal rate. Upon exiting the mould, the strand enters a roller containment section and secondary cooling chamber in which the solidifying strand is sprayed with water, or a combination of water and air (referred to as "air-mist") to

promote solidification. Once the strand is fully solidified and has passed through the straightener, the dummy bar is disconnected, removed and stored.

Depending on the design of the casting machine, the as-cast products of the continuous cast process are slabs, blooms, billets, or beam blanks. The cross sections of these products are shown in Figure 2. Billets have cast section sizes up to about 200 mm square. Bloom section sizes typically range from approximately 200 mm to 400 mm by 600 mm. Round billets include diameters of approximately 140 mm to 500 mm. Slab castings range in thickness from 50 mm to 400 mm, and over 2500 mm wide. The aspect ratio (width-to-thickness ratio) is used to determine the dividing line between blooms and slabs. An aspect ratio of 2.5:1 or greater constitutes an as-cast product referred to as a slab.

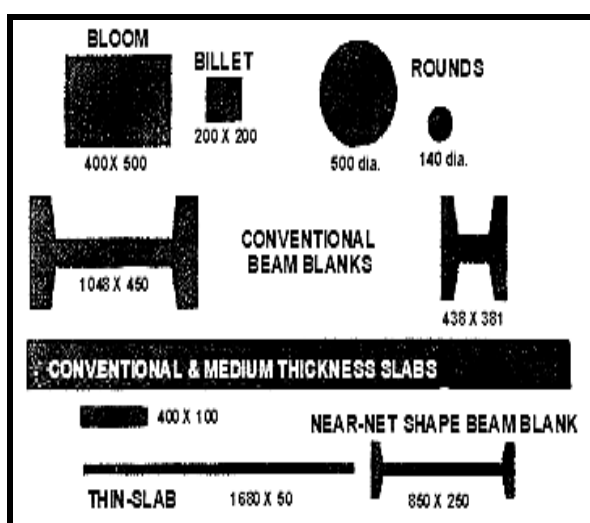

FIGURE 2: CONTINUOUSLY CAST SECTIONS

2. HEAT TRANSFER IN CONTINUOUS CASTING

By its nature, continuous casting is primarily a heat-extraction process. The conversion molten metal into a solid semi-finished shape involves the removal of the following forms of heat:

- superheat from the liquid entering the mould from the tundish.
- the latent heat of fusion at the solidification front as liquid is transformed solid, and finally the sensible heat (cooling below the solidus temperature) from the solid shell

These heats are extracted by a combination of the following heat-transfer mechanisms:

- convection in the liquid pool.
- heat conduction down temperature gradients in the solid shell from the solidification front to the colder outside surface of the cast, and
- external heat transfer by radiation, conduction and convection to surroundings.

Also not less important is heat transfer before the molten metal is poured into the mould. For instance, in the casting of steel, heat transfer is important before the steel enters the mould because control of

superheat in the molten steel is vital to the attainment of a predominantly equiaxed structure and good internal quality. Thus, conduction of heat into ladle and tundish linings, the preheat of these vessels, convection of the molten steel and heat losses to the surroundings also play an important role in continuous casting.

Because heat transfer is the major phenomenon occurring in continuous casting, it is also the limiting factor in the operation of a casting machine. The distance from the meniscus to the cut-off stand should be greater than the metallurgical length, which is dependent on the rate of heat conduction through the solid shell and of heat extraction from the outside surface, in order to avoid cutting into a liquid core. Thus, the casting speed must be limited to allow sufficient time for the heat of solidification to be extracted from the strand.

Heat transfer not only limits maximum productivity but also profoundly influences cast quality, particularly with respect to the formation of surface and internal cracks. In part, this is because metals expand and contract during periods of heating or cooling.

That is, sudden changes in the temperature gradient through the solid shell, resulting from abrupt changes in surface heat extraction, causes differential thermal expansion and the generation of tensile strains. Depending on the magnitude of the strain relative to the strain-to-fracture of the metal and the proximity of the strain to the solidification front, cracks may form in the solid shell.

The rate of heat extraction also influences the ability of the shell to withstand the bulging force due to the ferrostatic pressure owing to the effect of temperature on the mechanical properties of the metal.

Therefore, heat transfer analysis of the continuous casting process should not be overlooked in the design and operation of a continuous casting machine.

3. MATHEMATICAL MODEL

The importance of mathematical modeling of the continuous casting process can be seen in situations where the following are necessary.

- Simulation of an existing casting machine with a view to learning more about its operation;
- Prediction of effects of a change in a casting parameter on the performance of an operating caster;
- Design of new casting machines.

In particular, most process engineers are probably interested in the effect of increasing the casting speed on machine operation as higher output is sought to match planned or existing production capacity. Do changes then need to be made to the mould length, spray system, and position of the cut-off strand.

Another area of interest to the process engineer is the minimization of internal cracks such as halfway or centerline cracks. These points are discussed in this section to show the importance of a mathematical model,

based on heat-transfer principles, in adjusting casting conditions and improving overall machine performance.

Increasing the casting speed will have the effect of decreasing the time that the strand spends in the mould and spray zones, and also of increasing the depth of the liquid pool. Looking first at the mould, a decrease in the mould dwell time will result in a thinner shell at the bottom of the mould. Since this may increase the danger of break-outs, an increase in the mould length should be considered. Here the mathematical model can assist us since it can calculate the shell thickness for different casting speeds and mould lengths.

Halfway or midway cracks are the result of reheating of the surface of the strand due to a sudden reduction in the rate of surface heat extraction as the strand moves into the secondary cooling zone. So, if the spray system is to be altered to avoid midway cracks, reheating of the surface of the strand must be minimized as much as is practicable.

How can this be achieved? A mathematical model can give part of the answer. For example, if the surface temperature distribution to be maintained through the sprays is specified, the mathematical model can provide the spray heat-flux distribution that is required to achieve it.

The following basic assumptions were made during the formulation of the mathematical model:

- The continuous casting process is steady state.
- A round billet is considered and radial symmetry assumed.
- Energy dissipation due to internal friction in the liquid state is neglected.
- The melt free surface is assumed to be covered with a protective slag layer, through which negligible heat is assumed to be lost.

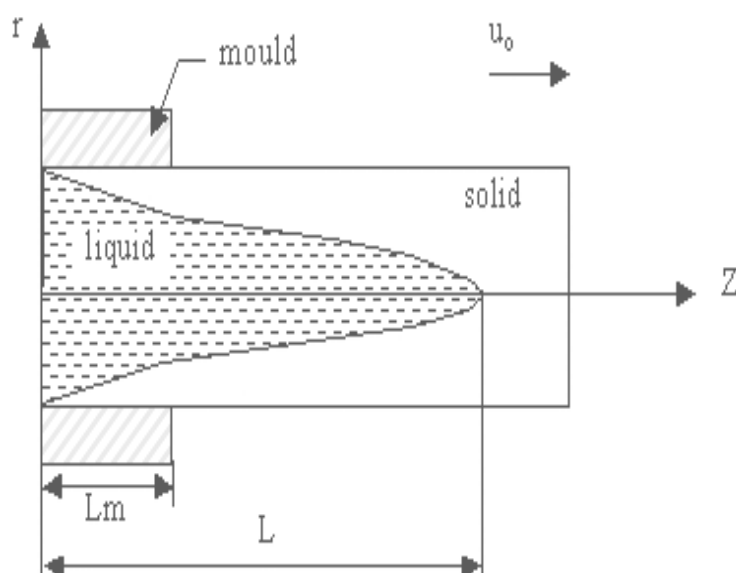

FIGURE 3: R-Z COORDINATES ATTACHED TO MOULD

The governing equation for the heat transfer analysis of continuous casting is:

$$\rho c \left(\frac{\partial T}{\partial t} + V \cdot \nabla T \right) = \nabla \cdot (k \nabla T) \quad (1)$$

Taking the above assumptions into account, the governing equation will be reduced to:

$$\rho c u \frac{\partial T}{\partial z} = \frac{\partial}{\partial z} \left(k \frac{\partial T}{\partial z} \right) + \frac{1}{r} \frac{\partial}{\partial r} \left(kr \frac{\partial T}{\partial r} \right) \quad (2)$$

The axial heat conduction is negligible compared to that convected due to the bulk motion of the moving strand. Thus, heat conduction is important solely in the radial direction. Under this condition the governing equation becomes:

$$\rho c u \frac{\partial T}{\partial z} = \frac{1}{r} \frac{\partial}{\partial r} \left(kr \frac{\partial T}{\partial r} \right) \quad (3)$$

The boundary conditions are:

- At the meniscus/free surface ($z = 0, 0 < r < R$)

$$T = T_p \quad (4)$$

- At the billet surface:

$$q_s = -k \frac{\partial T}{\partial r} \quad \text{or} \quad h(T - T_\infty) = -k \frac{\partial T}{\partial r} \quad (5)$$

- At the center due to axis symmetry ($r = 0$ and $0 \leq z \leq L$):

$$\frac{\partial T}{\partial r} = 0 \quad (6)$$

- At the liquid-solid interface ($r = r_i$ and $0 \leq z \leq L$):

$$T = T_m;$$

$$\left(k \frac{\partial T}{\partial r} \right)_l + \left(k \frac{\partial T}{\partial r} \right)_s = \rho Q_L \frac{dr_i}{dt} \quad (7)$$

4. ONE DIMENSIONAL TEST PROBLEM – DISCUSSION AND CONCLUSIONS

A one dimensional solidification problem was solved for a slab-like region of water with initial temperature of 10 °C when a temperature of -20 °C is applied on the outer surface shown in Figure 4. The slab was

modeled by using 20 two-node linear elements, 10 for the liquid part and 10 for the solid part. As solidification progresses, the mesh on the water is compressed and on the ice side is expanded;

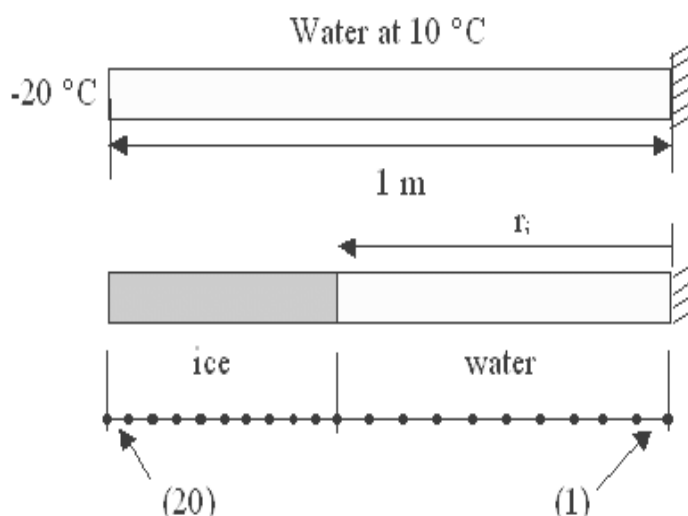

FIGURE 4. MODELING OF THE ONE DIMENSIONAL PROBLEM

The continuous casting process is introduced. One and two dimensional heat transfer analyses of the process are discussed. Results showed that such mathematical analysis of the process can help to control and optimize the process and to investigate the consequences of parameter changes without the safety and cost limitations of in-plant experiments.

The proposed algorithm can be used for the analysis of both stationary and moving solidification problems in which phase change occurs at a specific temperature.

NOMENCLATURE

T – Temperature; T_p – Pouring temperature; T_m – Solidification temperature; u – Casting speed; r – Density; c – Specific heat capacity; k – Thermal conductivity; q_s – Surface heat flux; Q_L – Latent heat; r_i – Interface position; N – Shape function; t – time; V – velocity vector; n – number of nodes

REFERENCES

- [1.] THOMAS, B. G., "Continuous Casting: Modeling", The Encyclopedia of Advanced Materials (Dantzig, J., Greenwell, A., Michalczyk, J., eds.), Pergamon Elsevier Science Ltd., Oxford, UK, Vol. 2, 1999
- [2.] CARSLAW, M. S. and JAEGER, C. J., Conduction of Heat in Solids, Oxford University Press, Oxford, 1973
- [3.] RUBINSKY, B. and CRAVALHO, E. G., "Analysis for the temperature distribution during the thawing of a frozen biological organ", Heat transfer – San Diego 1979, A.I.Ch. E. sympl. Ser, 75 (189), 81-88 (979)

- [4.] FIC, A., NOWAK, A. J., and BIALECKI, R., "Heat Transfer Analysis of the Continuous Casting Process by the Front Tacking BEM", Engineering Analysis with Boundary Elements, Vol. 24, p. 215-223, 2000
- [5.] CHOUDHARY, K. and MAZUMDAR, DIPAK, "Mathematical modeling of fluid flow, heat transfer and solidification phenomena in continuous casting of steel", Steel Research, 66, No. 5, 1995
- [6.] POPA Erika-Monica, Studiul privind tensiunile firului obținut la mașinile de turnat continuu (I), Analele Facultatii de Inginerie Hunedoara, Fascicola 4, 2002
- [7.] POPA Erika-Monica, Studiul factorilor de influență asupra defectelor de suprafață, Analele Facultatii de Inginerie Hunedoara, Fascicola 4, 2002
- [8.] POPA Erika-Monica, Experimentări privind influența parametrilor turnării asupra temperaturii suprafeței semifabricatului turnat continuu, Analele Facultatii de Inginerie Hunedoara, Fascicola 4, 2002
- [9.] POPA Erika-Monica, Studiul factorilor de influență asupra defectelor de formă, Analele Facultatii de Inginerie Hunedoara, Fascicola 4, 2002