



THE DC MOTOR CONTROL SYSTEM

Milan BALARA

University of Technology in Košice, Faculty of Manufacturing Technologies with seat in Prešov, Department of the Mathematics, Informatics and Cybernetics, SLOVAKIA

ABSTRACT:

The speed control system of an externally-excited DC motor without tachogenerator (TG) is actually a discrete control circuit where the motor current is intentionally cut-off so that the induced armature voltage may be sensed. This voltage (proportional to the angular speed of a motor) is stored in analog memory during one sample period and processed by the speed controller. That's how the speed control of a motor without TG is carried out – angular speed is sensed by the motor itself.

KEY WORDS:

tachogenerator, analog memory, controller, control system, discrete control circuit

1. INTRODUCTION

A feedback signal in speed control systems is usually provided by a tachogenerator. This solution is acceptable in most cases. However, there are applications in which using a TG is undesired or even impossible. This may be due to the following reasons:

- TG reduces the reliability of a system due to its fault,
- TG adds to the dimensions as well as the overall mass of a motor making it impractical for low-power drives,
- TG requires special supply circuit.

We know that externally-excited DC motor and tachogenerator are same as to their working principle and also their construction and we are trying to get a signal proportional to the angular speed from the motor itself.

2. WORKING PRINCIPLE

Externally-excited DC motor is also a generator of induced voltage proportional to the angular speed of a motor. Working principle of a DC motor speed control system without TG is based on processing the induced voltage of the motor itself instead of the voltage from TG. What appears as a problem associated with such a solution is getting this voltage noise-free. Also the effect of motor parameters shall be reduced to zero.

3. SOLUTION

At first we shall analyze the conditions in armature circuit controlled by a pair of power transistors (in T-connection). Circuit in Fig.2 shows the armature circuit in basic operating mode, e.g. one of the transistors is closed. Symbols: R_m – armature circuit resistance, L_m – armature circuit inductance, U_i – induced voltage, R_t – collector-emitter resistance of a power transistor and a suppression diode connected in parallel, U – source voltage, i – armature current. For such circuit the following equation holds true:

$$U - U_i - R_t i - L_m \frac{di}{dt} - R_m i - R_s i = 0 \quad (1)$$

The current in this circuit is sensed as a voltage drop across R_s . Because of this, a wire with zero potential is connected between R_s and voltage source U . Voltage between A_1 and zero potential is:

$$u_s = R_s i \quad (2)$$

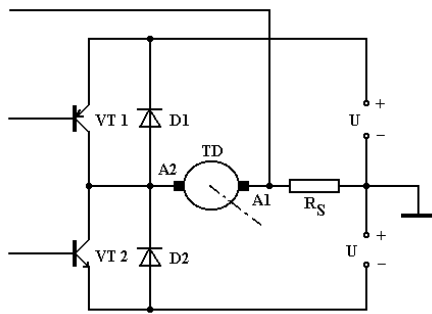

Figure 1. The Motor Armature Circuit

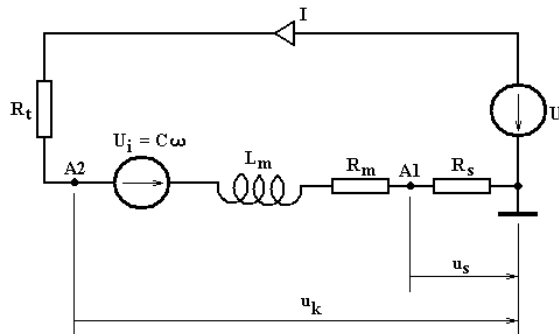

Figure 2. The Motor Armature Circuit In Normal Operating Mode

Voltage between A2 and zero potential is

$$u_k = U - R_s i \quad (3)$$

Thus the equation (1) may be re-written to this form:

$$u_k - u_s - U_i - L_m \frac{di}{dt} - R_m i = 0 \quad (4)$$

Voltage u_s is usually processed within the electronic control circuit as a signal proportional to the current. Voltage u_k can be processed as a feedback signal from the converter or it can be fed to the electronic control circuit. Then by subtracting these two signals by means of an op amp we get a signal roughly proportional to the angular speed

$$u_k - u_s = U_i + R_m i + L_m \frac{di}{dt} \quad (5)$$

In case

$$i = 0 \quad (6)$$

$$\frac{di}{dt} = 0 \quad (7)$$

the difference between these two voltages equals to the angular speed.

$$u_k - u_s = U_i = C\omega \quad (8)$$

The conditions (6) and (7) can be met by means of a current control circuit that is usually a part of a speed control circuit.

4. IMPLEMENTATION OF THE SPEED CONTROL CIRCUIT WITHOUT TG

In Fig.3 important circuits of the speed control circuit without TG are depicted. An analog gate is connected between the speed controller and current controller. A gate-effect (Fig.4) is provided by replacing a memory capacitor with R_H resistance connected between the terminal No.6 and the zero-potential.

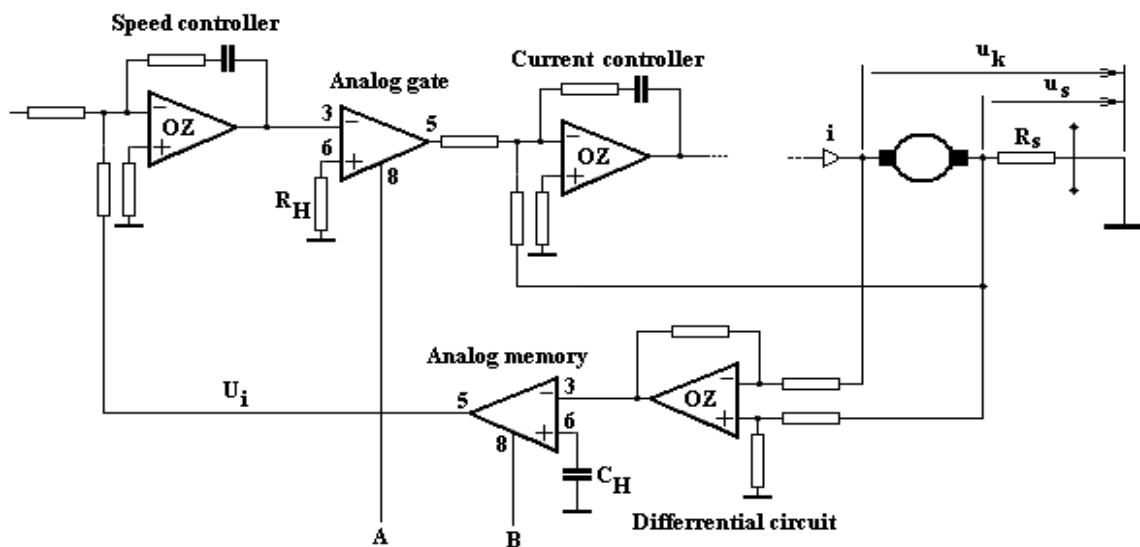

Figure 3. The speed control system circuit without tachogenerator

In case high-level voltage (H) is applied to the terminal No.8, it is passed to the output proportionally. If low-level voltage is fed to the input, the output voltage is zero. Thus the periodic change of voltage on terminal 8 allows for periodic cut-off of the current fed to the current controller.

Operation of the analog memory is depicted in Fig.5. In Fig.6 control signals for analog gate and analog memory are shown. The current controller provides a zero current (Fig.7) as well as a zero rate of change. The terminal voltage of the motor is at the output of differential circuit. This voltage is stored to the analog memory only after the transients of a current control pass away, e.g. when the conditions (6) and (7) are met. The voltage at the output of analog memory is then proportional to the angular speed and can be fed to the input of a speed controller. In Fig.11, the waveforms of TG voltage as well as the induced voltage at the output of analog memory are shown.

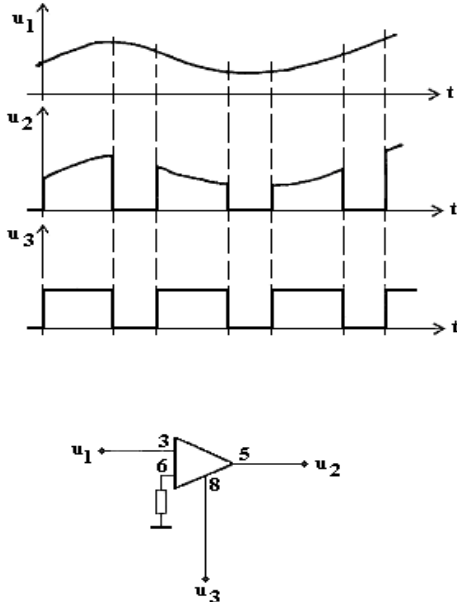

Figure 4. The operation of an analog gate

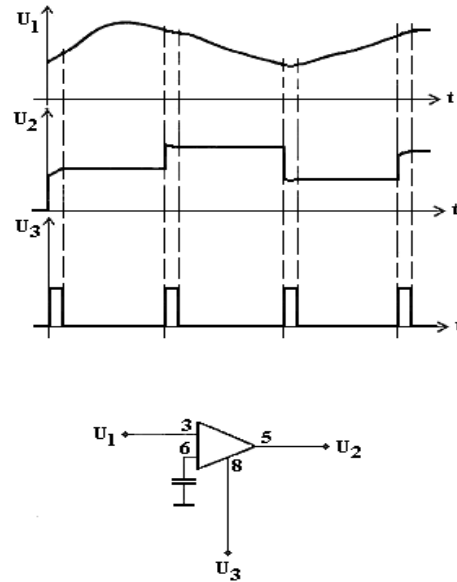

Figure 5. The operation of an analog memory

The utilization of this concept is probably possible even in converters with PWM voltage at the output as well as conventional motors. We suppose that in such case it would be necessary to decrease the frequency of A and B signals (700 Hz in our experiment).

5. CONCLUSIONS

A DC motor speed control system without TG shows satisfactory properties. By removing a TG it was possible to suppress unwanted behavior mentioned in the beginning of this article. This proposal was verified experimentally by means of a continuous converter and a special motor with small electromagnetic coefficient (HSM60). The results are shown in Fig.6-11. The described speed control system doesn't require a tuning of larger number of controllers compared to usual case. If the voltages u_k and u_s are fed to the differential circuit correctly, there is no possibility of getting positive feedback of angular speed signal during the operation when any maintenance was done on the system.

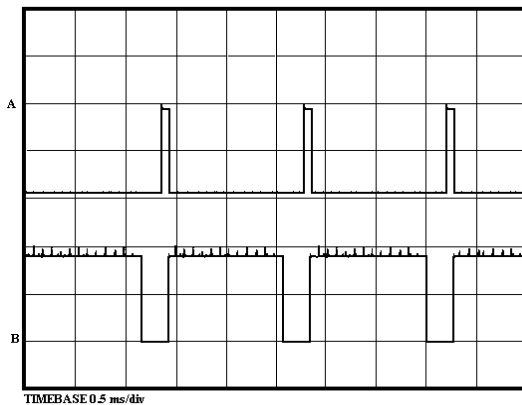

Figure 6. The analog gate and memory control signals

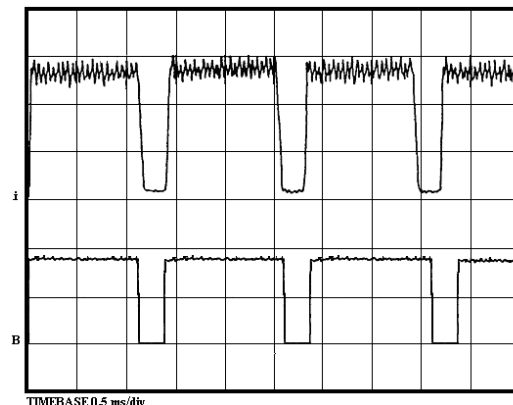

Figure 7. The analog gate control signal and the current signal

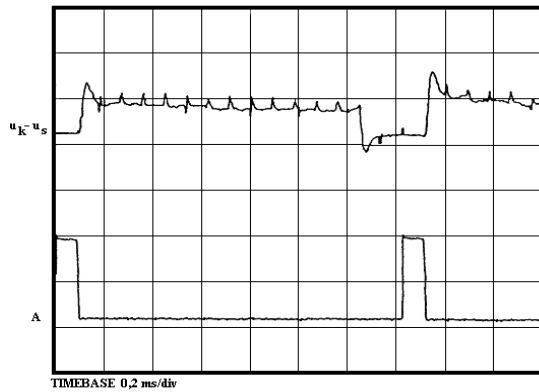

Figure 8. The voltage at the motor terminals and the analog memory control signal



Figure 9. The voltage at the motor terminals and the output voltage of the analog memory - detail

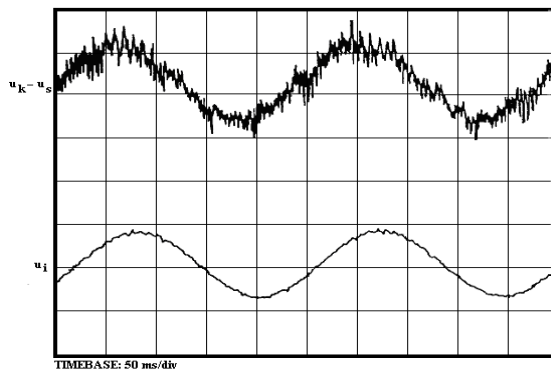

Figure 10. The voltage at the motor terminals and the output voltage of the analog memory

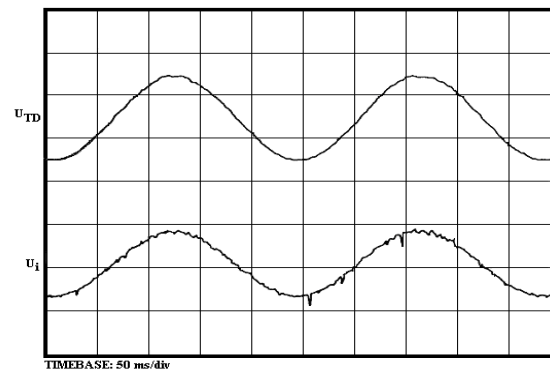

Figure 11. The comparison of tg voltage and the voltage at the output of analog memory

This type of a discrete control with specific frequency had an impact on the control range, which decreased from 1:6000 (TG) to 1:1500 (without TG), a fact almost certainly associated also with the lower quality of the angular speed signal (Fig.11).

Even though the control range of described system is lower, we suppose its utilization in such cases where the use of TG was prevented due to the reasons mentioned earlier.

NOTE:

This work was supported by the Science grant agency of Ministry of Education of Slovak Republic, VEGA, grant No. 1/4077/07 and the Institutional task of the Faculty of Manufacturing Engineering of Technical University in Kosice, no. 1/2009

APPENDIX

The time runnings of the some values in the important points of the described circuit.

REFERENCES

- [1] Alexandrov, A.G.: Sintez reguljatorov mnogomernych sistem. Moskva. Mašinstrojenije, 1986, str.4-43, 81-127.
- [2] Balara, M.: Tachogenerator angular acceleration measurement set [CS. Pat. No. 269 600]
- [3] Balara, D.- Balara, M.- Hošovský, A. : Rýchlostný systém s jednosmerným motorom bez tachodynamy. Elektrotechnický časopis ČSAV a SAV, roč. 39, č. 12, Bratislava, 1988, str. 920 - 928
- [4] Balara, M.: Rýchlostný servosystém s akceleračnou slučkou. Elektrotechnický časopis ČSAV a SAV, 1989, 40, č.5, str.390-397
- [5] Beneš, J.: Statistical dynamics of control circuits. Prague. SNTL 1965
- [6] Chan, S.M. – Athans, M.: Applications of Robustness Theory to Power System Models, IEEE, Transactions of Automatic Control, Vol. AC – 29, No. 1 January 1984, pp. 2 - 8
- [7] Hsia, S.: A New Technique for Robust Control of a Servo Systems. IEEE, Transactions on Industr. Electronics, Vol.36, Num.1, February 1989, str 1-7.
- [8] Hany, S. – Girgis, G.: Microprocessor – Based Digital Accelerometer and its Application in an Instrument for Motor Torque – Speed Characteristic Display During The Transient Interval. IEEE, Transactions on Industrial Electronics, Vol.IE – 33, No.1, February 1986, str.44-48.
- [9] Kalaš, V. – kol.: Nelineárne a číslicové servosystémy, Bratislava, Alfa, 1986.
- [10] Matyaš V.: Measurement, analysis and formation of random phenomenons. Prague. SNTL 1976