



ON THE ENERGETIC CHARACTERISTICS OF THE SHOCK INSULATORS OF RAILWAY VEHICLES

Ion COPACI

University „Aurel Vlaicu” Arad, ROMANIA

Abstract

The paper presents the results of experimental studies on the behaviour of bearing structures and shock insulators of railway vehicles during the shock caused by collisions.

The evolutions of energy parameters depending on the collision velocity are highlighted as well as the experimental values of certain kinematic and force parameters as response functions of the considered mechanical system to the action of excitations caused by the shocks that appear in use.

The paper contains notions related to the theory of shocks caused by collisions of railway vehicles as well as an experimental chapter which, together with the first part, highlight the importance of using shock insulators with a higher capacity for storing potential deformation energy, in order to reduce the maximum values of the response parameters of the considered mechanical system and also to protect the vehicles against the shocks that appear in use.

Keywords:

testing, collision, shock insulators, stored or dissipated potential deformation energy.

1. INTRODUCTION

Due to current tendencies to increase travel velocities and car masses by allowing increasingly larger axle loads, railway equipment shows a series of special problems regarding shock loads that appear during collisions. Collision of railway vehicles occurs during use, during car coupling operations, triage manoeuvres and during travel, as a consequence of sudden breaking or of a change in coupling systems [1].

The shock caused by railway vehicle collisions results in the transmission of forces and accelerations of considerable magnitudes, which determine:

- ✚ strains on the resistance structure of the cars (chassis, body) and bogies;
- ✚ strains of the internal equipment and facilities of passenger cars;
- ✚ strains of different devices, mechanisms, functional equipment of freight cars;
- ✚ accelerations transmitted to the transported freight, which can endanger their integrity and that of the anchoring or packaging systems;
- ✚ accelerations transmitted to passenger cars with considerable consequences on the comfort of the passengers.

In order to insulate and protect against longitudinal shocks, railway vehicles are equipped with shock insulators.

2. THE COLLISION PROCESS

The time evolution of the energetic parameters leads to the following observations on the collision process (figure 1) [3], [5], [6], [7]:

1. At the starting moment of the collision, $t = t_1 = 0$, the kinetic energy of the mechanical system composed of the vehicles, $E_c(t)$ is maximum.

2. On the interval $(0 - t_{12})$ the kinetic energy of the colliding car, $E_{c1}(t)$, decreases, and that of the collided car, $E_{c2}(t)$ increases. Their sum, $E_c(t)$, considerably decreases on the account of the transformation into stored potential energy by the bumpers W_e , cars $W_{ev} = W_{es} + W_{eb}$ and load W_{ef} .

3. At t_{12} , the kinetic energy of the cars is minimum:

$$E_c(t_{12}) = E_{c12} = \left[(m_1 + m_2) \cdot v_{12}^2 \right] / 2 \quad (1)$$

where:

m_1 – mass of the colliding car;

m_2 – mass of the collided car;
the stored potential energy being maximum:

$$E_p = W_e + W_{ev} + W_{ei} \quad (2)$$

4. On the interval $(t_{12} - t^*_{12})$ the process of transforming stored potential deformation energy into kinetic energy begins, together with the process of dissipating potential energy.

5. At the moment t^*_{12} the kinetic energy of the cars is equal to the kinetic energy of the cars at t_2 :

$$E_c(t^*_{12}) = E_c(t_2) - E^*_c = E^*_{c1} + E^*_{c2} \quad (3)$$

Furthermore, the sum between stored and dissipated potential energies (by the bumpers W_a , the cars W_{av} and the freight W_{ai}) is equal to the dissipated potential energy at t_2 :

$$(W_e(t^*_{12}) + W_{ev}(t^*_{12}) + W_{ei}(t^*_{12})) + (W_a(t^*_{12}) + W_{av}(t^*_{12}) + W_{ai}(t^*_{12})) = E_c - E_c(t^*_{12}) = E_c - E^*_c = W_a + W_{av} + W_{ai} \quad (4)$$

6. On the interval $(t^*_{12} - t_2)$ the kinetic energy of the cars E^*_c remains constant, under the conditions of the compensation of the drop in stored potential deformation energy by dissipation of potential energy from the system.

7. At the moment t_2 the energy balance is:

$$E_c = (m_1 \cdot v_1^2) / 2 = E^*_c + (W_a + W_{av} + W_{ai}) \quad (5)$$

8. Using buffers with superior dynamic characteristics, which store an increased amount of potential deformation energy, has as a direct consequence the decrease of the effects caused by the shock due to collision.

The diagram in figure 1 was drawn experimentally for the motion and energetic parameters resulting from the collision process of two cars equipped with high capacity shock insulators, category C (UIC – 526-1), the colliding car having a mass $m_1=80$ t, and the collided car $m_2=80$ t, collision velocity $v_1=3,028$ m/s. The experimental determinations comprised of $a_2(t)$, the forces transmitted through the shock insulators $F(t)$, their contractions $D(t)$, their stored potential energy W_e as well as the dissipated energy W_a .

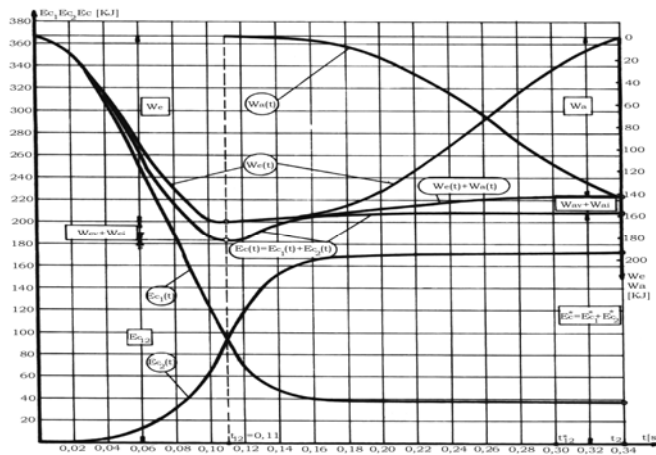

Figure 1

3. ENERGY FACTORS OF THE SHOCK CAUSED BY COLLISION

Against shocks that appear longitudinally during the use of the cars, the railway vehicles are equipped with shock absorbers (bumpers, central coupling dampeners) [8]. [9]. The use of bumpers or central coupling dampeners with high dynamic characteristics has the following consequences:

- ✚ the spectacular decrease of the maximum transmitted forces to the vehicles, with consequences on the protection of resistance structures by decreasing specific deformations and the stresses caused by the shock of collision;
- ✚ the lowering of the level of transmitted accelerations to the vehicles, down to a value that ensures a necessary protection of the freight, vehicle equipment and amenities, as well as an increased passenger comfort.

The following specific energy factors are defined, whose variation with the collision velocity $v = v_1 - v_2$ represents the energy characteristics of the shock caused by the vehicles' collision occurring on the time interval $(0 - t_2)$:

1. The $2\beta = f(v)$ factor [2], which characterizes the shock of railway vehicles, represents the ratio between the potential deformation energy stored by the shock absorbers W_e and the potential energy stored by the system composed of the two vehicles E_p :

$$2\beta = W_e / E_p \quad (6)$$

2. The $2\lambda = f(v)$ factor is the ratio between the potential deformation energy stored by the bearing structures of the vehicles W_{es} and E_p :

$$2\lambda = W_{es} / E_p \quad (7)$$

If the vehicles are identical from this point of view, then $\lambda_1 = \lambda_2 = \lambda$.

3. The $2\delta = f(v)$ factor represents the ratio between the potential deformation energy stored by the elastic elements of the vehicles' suspensions W_{eB} and E_p :

$$2\delta = W_{eB} / E_p \quad (8)$$

If the vehicles' suspensions are identical, it can be considered that $\delta_1 = \delta_2 = \delta$.

4. The $2\chi = f(v)$ factor represents the ratio between the potential energy stored by the equipment and the freight of the vehicles W_{ei} and E_p :

$$2\chi = W_{ei} / E_p \tag{9}$$

If the vehicles are identical from this point of view, then $\chi_1 = \chi_2 = \chi$. It is obvious that:

$$2\beta + 2\lambda + 2\delta + 2\chi = 1 \tag{10}$$

It is extremely important to take into consideration the fact that the resistance structures, the elastic elements of the suspension, the equipment as well as the nature and quantity of the freight are established by criteria other than that of the response to the longitudinal shock caused by collisions. Thus, the only practical method of reducing the effects of the shock is to increase the potential deformation energy stored by the shock insulators. Hence, it becomes clear why the $2\beta = f(v)$ factor represents the specific energy factor that characterizes the shock phenomenon in railway vehicles. This specific energy characteristic directly influences the unwanted consequences of the shock.

4. EXPERIMENTAL STUDY

The 95 m³ liquid tank car on 4 axles with 22,5 t/axle, was put up to the collision testing, according to the testing conditions imposed by the UIC in report RP17 of the ORE B12 committee. The loaded car collision tests are presented, during which the tested car, with mass $m_2 = 90$ t, was loaded with water and equipped with category C buffers (according to UIC 526-1); the colliding car was a freight car with mass $m_1 = 80$ t loaded with sand equipped with category C shock insulators (according to UIC 526-1) [4].

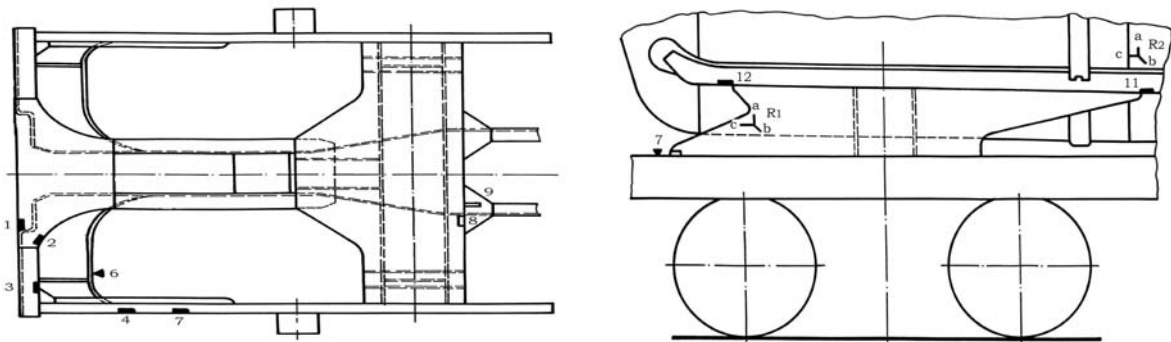

Figure 2

The placement of the transducers in order to experimentally determine the relative deformations is shown in figure 2, and the results of the measurements are presented in tables 1-3 (table 1 contains the results of the preliminary measurements, tables 2 and 3 show the results of the measurements for the series of 40 collisions).

Table 1.

Collision no.	V(km/h)	F ₁ (MN)	F ₂ (MN)	F(MN)	a (g)
1	8,9	0,48	0,57	1,05	3,04
2	11,2	0,70	0,79	1,49	4,19
3	13,5	0,92	1,05	1,97	5,33
4	15,0	0,98	1,14	2,12	6,09

Table 2.

Collision no.	V (km/h)	TER σ [N/mm ²]						
		1	2	8	11	4	6	9
10	15,0	243,1	-123,6	-173,0	-352,8	-164,8	214,8	-140,1
20	15,0	247,2	-119,5	-173,0	-342,0	-160,7	214,2	-144,2
30	15,0	239,0	-119,5	-181,3	-349,2	-160,7	226,6	-148,3
40	15,0	243,1	-119,5	-173,0	-352,8	-164,8	222,5	-140,1

Table 3.

Coll. no.	V (km/h)	TER σ [N/mm ²]			ROZETA R ₂ [N/mm ²]			
		3	7	12	σ_1	σ_2	σ_E	α (rad)
10	15,0	292,5	-243,1	214,2	-77,9	-162,1	140,4	1,61
20	15,0	271,9	-247,2	210,1	-77,9	-162,1	140,4	1,61
30	15,0	284,3	-243,1	214,4	-80,2	-162,8	140,1	1,60
40	15,0	271,9	-243,1	197,8	-76,6	-157,4	136,3	1,59

5. CONCLUSIONS

The study of the experimental results leads to the following conclusions:

- ✚ For a collision velocity of $v = 15$ km/h, the force transmitted to the shock insulators is in the range of (2,09 - 2,22) MN. The force $F = 3$ MN can be reached at velocities higher than the collision velocity of $v = 15$ km/h. Consequently, the repeated shock test (40 collision series) was conducted with the maximum collision velocity allowed by the RP17 ORE B12, meaning $v = 15$ km/h.
- ✚ The acceleration transmitted to the car at a collision velocity of $v = 15$ km/h is between (5,9 - 6,28) g, values that are inferior to those recorded in the case of using category A shock insulators.
- ✚ It is observed that the relative deformations and stresses, experimentally determined for the measurement points considered are below the flow limit $\sigma_c = 360$ N/mm², increased by 30% in accordance to the shock behaviour of the steels used in the construction of the railway car. Also, we consider that the use of shock insulators with a lower capacity for storing potential deformation energy would have led to the transmission of forces during the collision process that would have reached values of approximately 3MN, which would have led to the appearance of relative deformations in the most strained points which exceed the elasticity limit, thus creating the risk of occurrence of permanent deformations.
- ✚ The resistance structure of the chassis, the fixing elements for the tank on the chassis and the tank had an elastic behaviour. Residual deformations were not recorded at any measurement point. Investigations were conducted on the state of the car resistance structure, both visually and by using the penetrating liquid method, especially in the tank fixing region (transducers 11 and 12), as well as in the high strain areas (transducers 1 and 6) of the support beam. The collision testing prove that the technical solutions adopted correspond to the requirements imposed by vehicle use.

Using shock insulators with a high capacity for storing and dissipating potential deformation energy leads to the decrease of the unwanted effects of the shock caused by collision in the use of railway vehicles:

- ✚ permanent deformations of the elements of the resistance structures of railway vehicles;
- ✚ deterioration of amenities and functional equipment;
- ✚ ensuring the integrity of the transported freight and the fixing and packaging systems;
- ✚ eliminating the consequences that must be considered in appreciating passenger comfort.

REFERENCES

- [1] Copaci I., Trif E. ș.a. „Aplicarea metodei tensometrice pentru calcularea forței transmise și a lucrului mecanic înmagazinat de amortizoarele de șoc în timpul tamponării”. *Revista Transporturilor și Telecomunicațiilor nr. 3 la al II-lea Simpozion Național de Tensometrie cu participare internațională*, Cluj Napoca - 1980.
- [2] Copaci I. „Contribuții asupra comportării structurilor vagoanelor la solicitările provocate de șocul longitudinal produs la tamponare”. *Teza de doctorat, Universitatea „Politehnica” Timișoara, 1996.*
- [3] destinați echipării vehiculelor feroviare”. *Simpozionul Internațional „UNIVERSITARIA ROPET 2003”, 16-18 octombrie, 2003, pag. 85-90.*
- [4] Copaci I. „Cercetări asupra încercărilor de tamponare cu vagon gol și încărcat la vagonul cisternă pe 4 osii 95 mc pentru transport produse petroliere ușoare” - contract de cercetare I.C.P.V.Arăd pentru "ASTRA" Vagoane Arăd, 181/1993.
- [5] Sebeșan I., Copaci I., „Teoria sistemelor elastice la vehiculele feroviare”, Editura Matrix Rom București - 2008.
- [6] Tănăsioiu Aurelia, Copaci Ion, „Study on the Shock caused by Collision of Railway Vehicles”, *International Journal of Mechanics, ISSN 1998-4448, pag. 67-76, www.naun.org/journals/mechanics.*
- [7] Tănăsioiu Aurelia, Copaci Ion, „Study on the Behaviour of the Self-Unloading SSDT Train Upon the Shock Caused by Collisions”, *WSEAS Conferences, Computer and Simulation in Modern Science, vol. II, ISSN 1790-5117, ISBN 978-960-474-032-1, www.wseas.org.*
- [8] Aurelia Tanasoiu, Ion Copaci – Study on the evolution of kinematic parameters during the shock caused by railway vehicle collision, *Simpozionul Internațional “INTERPARTNER” 22-27 sept. 2008, Alushta, Crimea.*
- [9] Aurelia Tanasoiu, Ion Copaci – On the shock caused by railway vehicle collision, *Al XVII-lea Seminar International de științe Tehnice, “INTERPARTNER” 22-27 sept. 2008, Alushta, Crimea, Ucraina.*