

¹Abalo P'KLA, ¹Yawovi Mawuénya Xolali Dany AYTE

COMPARATIVE ANALYSIS OF BROUKOU AND KPASSIDÈ (TOGO) CLAY SOILS PERMEABILITY COEFFICIENT MEASURED FROM PORCHET AND VARIABLE LOAD PERMEAMETER TESTS

¹Civil Engineering department, Engineers High National School of University of Lome, TOGO

Abstract: Soil hydraulic conductivity is a geotechnical parameter commonly used in civil engineering works. It is necessary when designing an underground drainage system. There are two main approaches for determining and interpreting this parameter: in situ tests (example of the Porchet test) and laboratory tests (permeameter test). However, the results obtained through these two methods are generally not identical. The purpose of this work is to assess the permeability coefficient of Broukou and Kpassidè clay soils (two (2) localities in northern Togo), using the Porchet test and the variable load permeameter test. It turns out that the Porchet method on clay soils gives permeability results of the order of 10^2 times higher than those obtained with the variable load permeameter test carried out in laboratory.

Keywords: permeability coefficient; clay soils; Porchet test; variable load permeameter; dry density

1. INTRODUCTION

Soil permeability is its ability to let water flow through it. This soil property is of practical interest in civil engineering in the design and construction of structures directly in contact with water. A permeable or impermeable soil can be sought depending on the role it is called upon to play in the stability or functioning of the structure. There are two types of approach for assessing soil permeability: in situ studies, in particular the Porchet test, and in laboratory, in this case, the permeameter test [1-2]. In both cases, the experimental procedures differ, the interpretation of the results varies and it is very remarkable that the values of hydraulic conductivity (permeability coefficient) measured on the soil by the in situ and laboratory methods are not identical. This situation therefore generates the need to be able to establish correlations between the permeability coefficients determined in situ and those obtained in laboratory. This article presents the results obtained in situ by the Porchet test and in laboratory using the variable load permeameter with a view to estimating the order of size of the difference between the permeability values obtained for the two types of test. The tests were carried out on clays soils coming from Broukou and Kpassidè, two localities located in the North of Togo, and used in the construction of a water storage for which it was necessary to evaluate the basin soil permeability.

2. MATERIAL AND METHOD

The methodological approach adopted consists in measuring the permeability of the clay soils of Broukou and Kpassidè (Figure 1 locates the two sites on a Togo map) using tests Porchet and variable load permeameter. In fact, soil samples are taken at the Porchet test site and compacted in laboratory at a density close to that of the site in order to carry out the permeability test in laboratory. The values of permeability in situ and in laboratory can then be comparable because they are determined on samples of the same density. Soil identification tests are also carried out (particle size distribution [3], Atterberg limits [4], water content [5], and Proctor tests [6]) in order to know the material geotechnical nature and to carry out their GTR (Guide of Road Earthworks) classification [7].

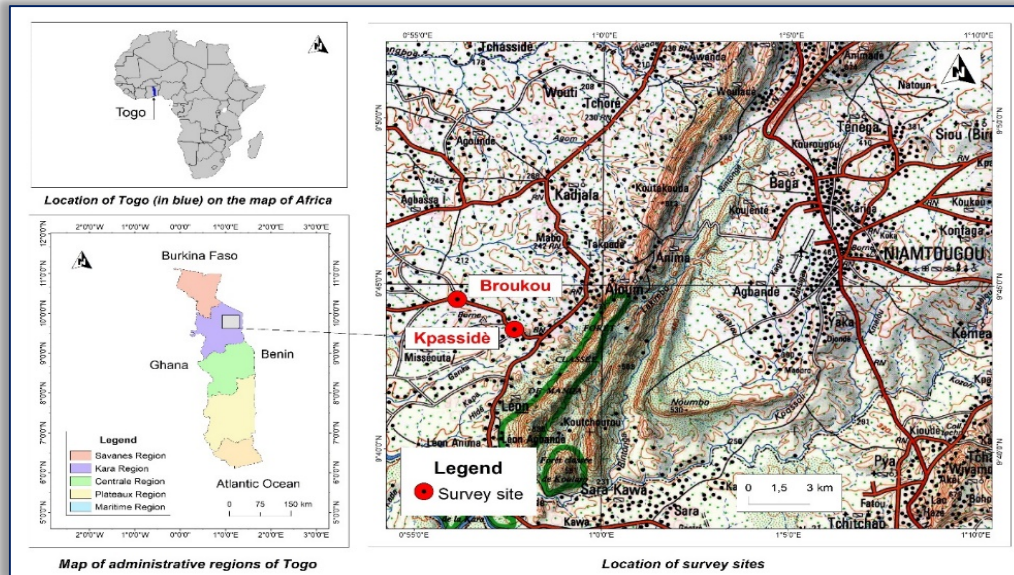

Figure 1. Location of survey and sampling sites

— Porchet test method

The Porchet test consists in digging a cylindrical cavity in the soil, filling it with water up to a certain level and measuring water infiltration speed after saturating the soil [8]. Figure 2 illustrates the Porchet test principle.

In practice (after stripping the upper vegetal layer of the soil), the cavity is cylindrical 55 cm deep (the objective being to make the measurements on a depth of 50 cm) and is carried out using a manual auger of 80 mm diameter, being careful not to smooth the edges (Figures 3 and 4).

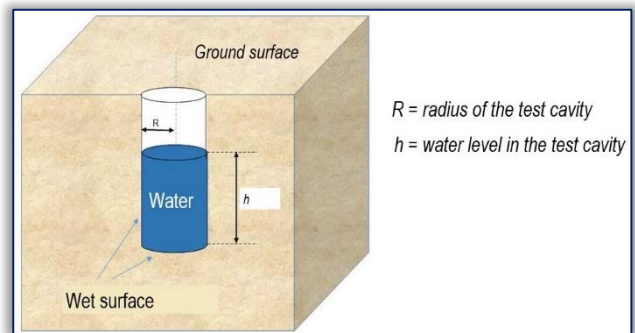

Figure 2. Principle schema of Porchet test [8]



Figure 3. Manual auger



Figure 4. Porchet test cavity



Figure 5. Cavity filled with water



Figure 6. Measurement of water level drop

The cavity is then filled with water for at least 4 hours to saturate the soil with water (Figure 5). Meanwhile, the values of the water free surface level are recorded at regular intervals of time in order to determine whether the permanent infiltration regime (characterized by the constancy of the water volume infiltrated per unit of time) is reached. Once the permanent regime is reached and therefore the soil is saturated, the water free surface level in the cylindrical cavity is measured every 2 minutes for 60 minutes (Figure 6). The differences between the cavity test depth (50 cm) and the heights measured give the water heights in the cavity at the different measurement times. After the water level measurements, it is represented the graph $(t; \ln(h + \frac{R}{2}))$ from a cloud of dots (Figure 7).

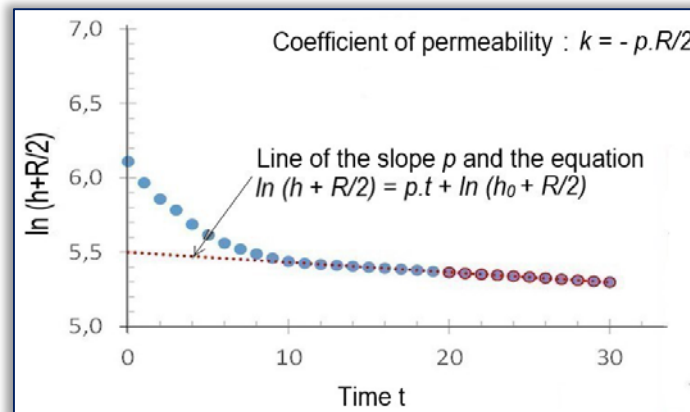

Figure 7. Permeability curve [8]

The final part of this curve is a segment of a line whose equation is given by [8]:

$$\ln\left(h + \frac{R}{2}\right) = -\frac{2k}{R}t + \ln\left(h_0 + \frac{R}{2}\right) \quad (1)$$

where:

h is the height of water (cm) in the cavity at time t (min);

h_0 is the height of water in the cavity at the initial time of the measurements and is equal to 50 cm;

R is the radius of the cavity and is equal to 4 cm;

k is the permeability coefficient (cm/min);

$-\frac{2k}{R} = p$ is the slope of the line.

The slope of the line can be determined graphically. From the value of p found graphically, the permeability coefficient k is deduced using the formula [8]:

$$k = -\frac{pR}{2} \quad (2)$$

The value of the permeability coefficient k defined by equation (2) is thus evaluated at the temperature T of the test. The water flow through a material depends on the water viscosity μ which varies according to the temperature [source]. It is therefore necessary to reduce the value of the permeability coefficient ($k = k_T$) measured at temperature T to a standard value (k_{20}) corresponding to a reference temperature taken equal to 20°C.

The permeability coefficient k_{20} (in m/s) at 20°C is then obtained using equation (3) [8]:

$$k_{20} = k_T \times b = k_T \times \frac{\mu_T}{\mu_{20}} \quad (3)$$

where:

» $b = \mu_T/\mu_{20}$ is a coefficient established by Jaynes [9] and defined as follows:

$$b = \exp(2,44 \times 10^{-2}(20 - T) + 1,8 \times 10^{-4}(20 - T)^2 + 2,5 \times 10^{-6}(20 - T)^3)$$

where T represent the test temperature (°C);

» k_T is the permeability coefficient (m/s) measured at the temperature T (°C) of the test;

» μ_T is the kinematic viscosity (m²/s) of the water at the temperature T of the test;

» μ_{20} is the kinematic viscosity of the water at 20°C (m²/s).

It is important to mention that the calculation of k using the Porchet method is based on the strong assumption of the hydraulic gradient equal to 1.

— Variable load permeameter test method

The permeability test in laboratory consists in subjecting a soil sample to a hydraulic load difference, so as to establish a one-dimensional flow between its lower and upper extremities [10]. Due to the clay nature of the materials, the permeability test is carried out at variable hydraulic load and according to standard NF X30-441 [11]. The principle of the variable load permeameter test is presented in Figure 8. The device used for the tests is the permeameter with constant or variable load (Figure 9). This allows testing at constant or variable load.

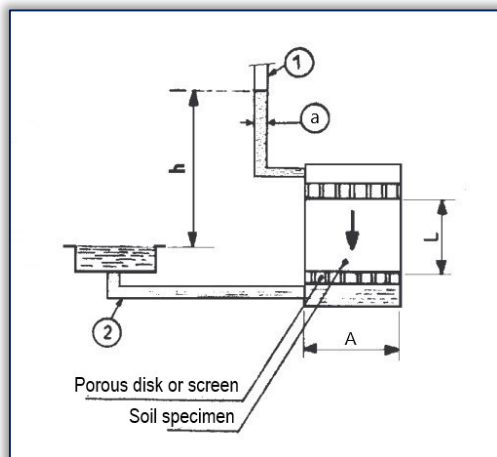

Figure 8. Principle scheme of variable load permeameter [10]



Figure 1. Constant or variable load permeameter

The objective of the work is to conduct a comparative study between the in situ permeability and that obtained in laboratory. So, the material was compacted in laboratory by varying the compaction energy so as to have a dry density substantially equal to that of the material in situ. The soil sample is introduced into three (3) layers in the permeameter compaction mold. Each layer is compacted using a normal Proctor rammer at $N = 10, 15$ or 25 blows depending on the energy to be applied for the test. The dry density (γ_d) and the void ratio (e) of the compacted sample are then determined.

Before starting the test, it must be ensured that the test sample is completely saturated with water. To do this, the entire compaction permeameter containing the compacted sample is placed in an immersion tank for 48 hours. After this saturation phase, the measurements are made as follows:

- » The time t , necessary for the water level in the manometric tube of the permeameter to go from a height h_1 to a height h_2 , is measured; five (5) measurements are made for the same soil specimen;
- » The temperature T of the water in the permeameter tank is noted;
- » At the end of the test, the soil sample is removed from the mold and a part of it is taken for determining the dry density and the water content.

The permeability coefficient k (in m/s) at variable load is calculated using equation (4) [11]:

$$k = \frac{a \times L}{A \times t} \ln \left(\frac{h_1}{h_2} \right) \quad (4)$$

where:

- » a is the section of the manometric tube (m^2);
- » L is the height of the soil sample (m);
- » A is the section of the soil sample (m^2);
- » t is the time necessary (s) for the water level in the manometric tube to go from a height h_1 to a height h_2 .

The value of the permeability coefficient $k = k_T$ obtained at the temperature T of the test is then reduced to the reference value k_{20} using equation (3).

3. RESULTS AND DISCUSSIONS

— Results of nature and state parameters identification

The results of nature and state parameters identification tests, as well as those of the normal Proctor test, are presented in Tables 1 and 2 and in Figure 10. Broukou soil is fine and plastic. According

to the GTR classification of soils, these are marly clays or very plastic silts (class A3). Kpassigé soil is also fine and plastic but is of class A2 (fine clay sands, silts, clays and marls which are not very plastic). It should be noted that the two materials have fairly close optimum water contents and densities.

Table 1 : Results of nature and state parameters identification tests

Material	< 80 μm (%)	$D_{\text{max}}^{(1)}$ (mm)	Liquidity limit w_L (%)	Plasticity index I_P (%)	Absolute density γ_s (g/cm ³)	Water content w (%)	Dry density γ_d (g/cm ³)	GTR class
Broukou clay soil	70	2,5	44	26	2,53	7,28	1,73	A3
Kpassidè clay soil	81	0,315	45	24	2,43	3,32	1,75	A2

(1) Diameter for which 95% of grains have a smaller dimension

Table 2 : Optimal Proctor values of the studied clays soils

Material	Optimal moisture content w_{OPN} (%)	Optimal dry density $\gamma_{d OPN}$
Broukou clay soil	12,2	1,84
Kpassidè clay soil	13,2	1,82

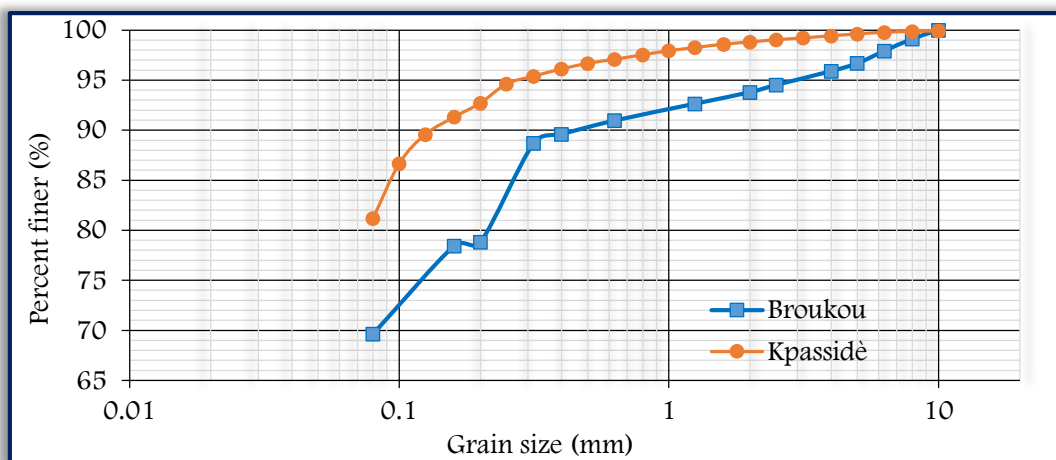

Figure 2. Particle size curves of Broukou and Kpassidè clay soils

— Permeability test results and discussions

» Porchet test results

The results of the Porchet tests on Broukou and Kpassidè clay soils are presented in Table 3. The permeability coefficients k_{20} of Broukou and Kpassidè clays soils are respectively $1.825 \times 10^{-6} \text{m/s}$ and $1.008 \times 10^{-6} \text{m/s}$ for respective dry densities of 1.73 and 1.75.

Table 3 : Porchet test results

Broukou clay soil					
Survey point	Cavity radius R (cm)	Permeability curve slope p	Permeability coefficient k_T (m/s)	Average k_T (m/s)	Square root of mean deviation e_m (m/s)
Br1	4	-0,006466	$2,155 \times 10^{-6}$	$2,476 \times 10^{-6}$	$2,937 \times 10^{-7}$
Br2	4	-0,008751	$2,917 \times 10^{-6}$		
Br3	4	-0,007070	$2,357 \times 10^{-6}$		
T (°C)	$b = \mu_T / \mu_{20}$	μ_{20} (m ² /s)	μ_T (m ² /s)	Permeability coefficient k_{20} (m/s)	Dry density γ_d (g/cm ³)
33,6	0,737	1,007	0,742	$1,825 \times 10^{-6}$	1,73
Kpassidè clay soil					
Survey point	Cavity radius R (cm)	Permeability curve slope p	Permeability coefficient k_T (m/s)	Average k_T (m/s)	Square root of mean deviation e_m (m/s)
Kp1	4	-0,003775	$1,258 \times 10^{-6}$	$1,434 \times 10^{-6}$	$1,168 \times 10^{-7}$
Kp2	4	-0,004735	$1,578 \times 10^{-6}$		
Kp3	4	-0,004393	$1,454 \times 10^{-6}$		
T (°C)	$b = \mu_T / \mu_{20}$	μ_{20} (m ² /s)	μ_T (m ² /s)	Permeability coefficient k_{20} (m/s)	Dry density γ_d (g/cm ³)
35,9	0,703	1,007	0,708	$1,008 \times 10^{-6}$	1,75

» **Variable load permeameter tests results**

Table 4 presents the average values k_T and k_{20} of the permeability coefficient obtained in laboratory using the permeameter as a function of dry densities (γ_d), void ratio (e) and water contents (w). By carrying out a linear interpolation, the permeability value corresponding to that of the in situ density can be determined (Table 5). A permeability coefficient k_{20} equal to 2.360×10^{-8} for Broukou clay and 5.538×10^{-9} for Kpassidè clay is obtained.

Table 4 : Summary of the results of laboratory permeability tests on Broukou and Kpassidè clays

Broukou clay soil								
Number N of blows	Permeability coefficient k_T (m/s)	Permeability coefficient k_{20} (m/s)	Water contents w (%)		Dry densities γ_d (g/cm ³)		Void ratio e	
			initial	final	initial	final	initial	final
10	$7,496 \times 10^{-7}$	$6,258 \times 10^{-7}$	12,61	22,1	1,57	1,58	0,611	0,601
10	$1,213 \times 10^{-7}$	$9,190 \times 10^{-8}$	14,61	19,7	1,64	1,66	0,543	0,524
15	$1,658 \times 10^{-8}$	$1,384 \times 10^{-8}$	14,81	17,8	1,72	1,74	0,471	0,454
15	$2,835 \times 10^{-9}$	$2,237 \times 10^{-9}$	12,14	15,68	1,77	1,79	0,429	0,413
25	$1,529 \times 10^{-9}$	$1,277 \times 10^{-9}$	14,38	15,55	1,78	1,81	0,421	0,398
Kpassidè clay soil								
Number N of blows	Permeability coefficient k_T (m/s)	Permeability coefficient k_{20} (m/s)	Water contents w (%)		Dry densities γ_d (g/cm ³)		Void ratio e	
			initial	final	initial	final	initial	final
10	$5,031 \times 10^{-8}$	$3,902 \times 10^{-8}$	12,09	20,17	1,61	1,64	0,509	0,422
10	$1,651 \times 10^{-8}$	$1,297 \times 10^{-8}$	13,17	17,60	1,71	1,73	0,421	0,405
15	$2,197 \times 10^{-9}$	$1,822 \times 10^{-9}$	13,29	17,47	1,73	1,76	0,405	0,395
15	$1,529 \times 10^{-9}$	$1,238 \times 10^{-9}$	14,05	16,48	1,77	1,78	0,373	0,365
25	$5,865 \times 10^{-10}$	$4,587 \times 10^{-10}$	13,13	15,87	1,83	1,84	0,328	0,321

Note: The initial values correspond to those obtained from the compaction of the soil sample before immersion and the final values correspond to those obtained at the end of the test.

» **Comparison between Porchet and variable load permeameter tests results**

The comparison is based on the average values of permeability coefficients obtained at 20°C (k_{20}) for each type of test. These values are summarized in Table 5 with the corresponding dry densities.

Table 5 : Proportionalities between in situ and laboratory permeability coefficients for Broukou and Kpassidè clay soils

Material	In situ values		Laboratory values		$\frac{k_{20 \text{ in situ}}}{k_{20 \text{ labo}}}$	$\frac{k_{20 \text{ labo}}}{k_{20 \text{ in situ}}}$
	$k_{20 \text{ in situ}}$ (m/s)	γ_d	$k_{20 \text{ labo}}$ (m/s) *	Final γ_d		
Broukou clay soil	$1,825 \times 10^{-6}$	1,73	$2,360 \times 10^{-8}$	1,73	$7,734 \times 10^1$	$1,293 \times 10^{-2}$
Kpassidè clay soil	$1,008 \times 10^{-6}$	1,75	$5,538 \times 10^{-9}$	1,75	$1,820 \times 10^2$	$5,494 \times 10^{-3}$

* Value obtained by linear interpolation

From Table 5, it is possible to represent the diagrams in Figure 11 showing the comparison between permeability coefficients determined in situ and those obtained in laboratory.

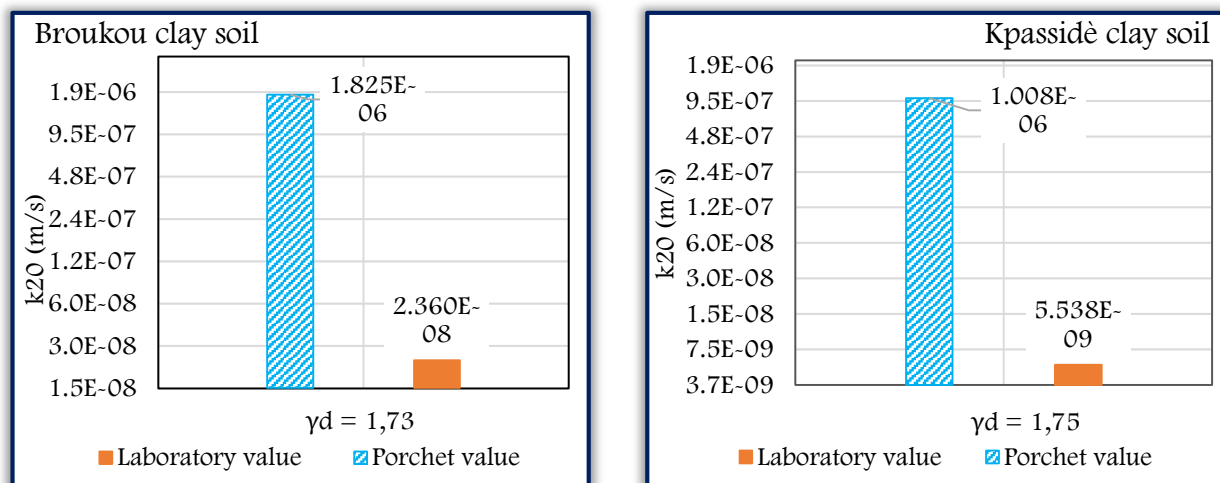

Figure 3. Comparative diagrams of Porchet and variable load permeameter tests results on Broukou and Kpassidè clays soils

Analysis of Table 5 shows that the permeability coefficients at 20 ° C determined by the Porchet test on Broukou and Kpassidè clays soils are about 10² times greater than the permeability coefficients obtained with the variable load permeameter.

4. CONCLUSION

The study presented in this article consisted in determining the permeability coefficients of Broukou and Kpassidè clays soils by the Porchet test and the variable load permeameter test. The objective is to compare the permeability values obtained in situ and in laboratory and to establish correlations between these permeability coefficients. Thus, the permeability coefficients at 20 ° C determined by the Porchet test on Broukou and Kpassidè clays soils in situ are of the order of 10² times greater than the permeability coefficients obtained with the variable load permeameter test done in laboratory. Studies should be continued on materials of a different nature, notably sands, silts and laterites in order to see if these differences in values are of a general order and of the same amplitude.

References

- [1] Nagy L., Tabákcs A., Huszák T., Mahler A., Varga G., Comparison of permeability testing methods, Proceedings of the 18th International Conference on Soil Mechanics and Geotechnical Engineering, Paris, pp 399-402, 2013
- [2] Amr F. Elhakim, Estimation of soil permeability, Alexandria Engineering Journal Vol. 55, 2631–2638, 2016, <http://dx.doi.org/10.1016/j.aej.2016.07.034>
- [3] Association Française de Normalisation (AFNOR), NF EN ISO 17892-4: Geotechnical investigation and testing - Laboratory testing of soil - Part 4: Determination of particle size distribution, January 2018
- [4] Association Française de Normalisation (AFNOR), NF P 94-051 - Soil : investigation and testing - Determination of Atterberg's limits - Liquid limit test using Casagrande apparatus - Plastic limit test on rolled thread, 1993.
- [5] Association Française de Normalisation (AFNOR), NF P 94-050 - Soils: investigation and testing - Determination of moisture content - Oven drying method, 1995.
- [6] Association Française de Normalisation (AFNOR), NF P 94-093 - Soils: investigation and testing - Determination of the compaction reference values of a soil type - Standard proctor test - Modified proctor test, 2014.
- [7] Association Française de Normalisation (AFNOR) NF P11-300- Earthworks - Classification of materials for use in the construction of embankments and capping layers of road infrastructures, 1992
- [8] J.-P. Montoroi, M. Peraudeau, P. Zante, Essais de mesure de la perméabilité des sols de la séquence de Koubalan par la méthode Porchet, 1986.
- [9] K. Lachgueur, Chapitre II: Etude de la perméabilité.
- [10] M. Khemakhem, Z. Bouarada, Travaux pratiques de géotechnique.
- [11] Association Française de Normalisation (AFNOR), NF X30-441: Waste - Laboratory determination of the permeability coefficient of a saturated material - Permeability tests using a rigid wall permeameter at constant/variable hydraulic head, 2008.



ANNALS of Faculty Engineering Hunedoara – International Journal of Engineering
ISSN 1584 - 2665 (printed version); ISSN 2601 - 2332 (online); ISSN-L 1584 - 2665
copyright © University POLITEHNICA Timisoara,
Faculty of Engineering Hunedoara,
5, Revolutiei, 331128, Hunedoara, ROMANIA
<http://annals.fih.upt.ro>