



¹K. A. ADEBIYI, ²E.O. SANGOTAYO

DEVELOPMENT OF MATHEMATICAL MODELS FOR THERMAL CONDUCTIVITIES OF SOME ENGINEERING MATERIALS

^{1,2} Ladoko Akintola University of Technology, Mechanical Engineering Dept, Ogbomosho, NIGERIA

Abstract: Thermal conductivity equipment was developed using locally available materials. The equipment consists of the sample holder, the thermometer probe cavity, the heating cavity and the structural wooden frame, performance evaluation was carried out using four different materials (iron, brass, mild steel and aluminum). The experimental studies were carried out at different time; 300 seconds interval (from 300 through 1500seconds) on the four materials and temperatures reading were recorded. The results of experimental studies were modeled to develop regression equations for predicting thermal conductivities of the materials. Analysis of Variance (ANOVA) and statistical t-test were carried out to validate the models at 5% level of significance. The experimental results show that Aluminum has highest thermal conductivity with respect to temperature while a linear model with coefficient of determination, $R^2(0.9097)$ was obtained. Statistical tests for each of models developed and the experimental results show that there is no significant difference at 5% level of significance. It is concluded that the models developed could be used to predict thermal conductivity for the four materials with good accuracy with respect to time.

Keywords: Performance evaluation, thermal conductivity, ANOVA

1. INTRODUCTION

Thermal conductivity is defined as the quantity of heat transferred through a unit thickness of material in a direction as a result of temperature difference under-steady state boundary condition (Karawacki & Gustavson, 1994; Rajput, 2006). This implies that heat conduction occurs when a body is exposed to a temperature gradient and becomes serious when different parts of a body experience differential temperature ratings.

The measurement of thermal conductivity therefore involves the measuring of temperature difference and also depends on its properties of the materials. Typical among them are structure, density, moisture content and operating conditions like pressure and temperature (Rajput, 2006, Meadan, 1990; David, 2008). Materials with high thermal conductivities are good conductors of heat, whereas materials with low thermal conductivities are good thermal insulator (Meadan, 1990).

Methods of measuring thermal conductivity have been reported as the comparative method, the absolute method etc. each of it is suitable for a limited range of materials, depending on the thermal properties and temperature (Meadan, 1990). Various relatively new efforts of suitable methods for measuring thermal conductivity have been performed by Srivastava (1990). Advances in electrical and electronic products have resulted in the development of high power component linkage through high power circuitry conduction paths. This process requires thermal and electrical insulation from heat dissipation and thermal conduction for save operation as observed by Kaufman, 1994. For good conductors of heat, sealers bar method has been proposed by Callender, (1987) whereas for poor conductors of heat, disc method can be used by Ogunsola, (2007). As good as experimental results, it is highly labourious, time consuming and susceptible to risk.

Thermal conductivity of electrical materials is an important parameter that should be easily determined at any practicing laboratory. Thus, this is a worthwhile suitable reproducible device for the estimation of thermal conductivity of metallic materials that is appropriate for laboratory research purposes and undergraduate experiments. Thus established results can be used to develop mathematical expression





that predicts any typical thermal conductivity. The aim of this work is to develop mathematical model for determining the thermal conductivity of cast iron, brass, aluminum and steel.

2. MATERIAL AND METHOD

☐ Design Consideration

The thermal conductivity apparatus was designed to carry a maximum of five test pieces with specified weight, and diameter with consideration to bending and shear loads resistance (Ajimotokun & Ogunsola, 2009).

☐ Design Factors

Factors considered are stress, strength of the material and type of loading. Mild steel was selected as the sample or specimen holder due to its high strength and toughness.

☐ Design Calculations

The specimen holder diameter (d) is 14mm and the specimen holder Length (L) is 200mm.

$$\text{Area of Rod} = \frac{\pi d^2}{4} \quad (1)$$

Using eq. 1, Area of Rod is calculated as 153.94 mm². Yield load of mild steel rod is 98N.

$$\text{Yield stress} = \frac{\text{Yield load}}{\text{Area}} \quad (2)$$

Using eq. 2, Yield stress of rod is obtained as 0.637 N/mm². Moreover weight of material is given as

$$\text{Weight} = \text{mass, (kg)} \times \text{acceleration due gravity, (m/s}^2) \quad (3)$$

Thus, eq. (3) was used to obtain following weights:

- » weight of aluminum is 9.8N
- » weight of brass is 19.6N
- » weight of mild steel is 19.6N
- » weight of cast iron is 19.6N

Total working weight of the four specimens

$$\text{working weight} = \text{total weight} \times \text{safety factor} \quad (4)$$

Thus, total working weight of the four specimens is 64.484 N. Specimen disc diameter (d) is 47.5mm

Using eq. (1), Area of one disc is 7088.218 mm². Area of the four specimen discs is 2 28352.875 mm².

$$\text{Stress on specimen} = \text{Force} / \text{Area} . \quad (5)$$

Using eq. (5), yield stress that each specimen can withstand is 2.274x10⁻³ N/mm²

☐ Material Specifications

Detail of material selections are shown in Table 1. The sample holder was designed to hold the disc specimens the heating cavity has an inserted rod heater with an electrically, powered supply system which allows the flows of heat, the structural wooden frame was designed to give the apparatus balance, conformity and shape, and the thermometer probe cavity is to take temperature reading by the use mercury in glass thermometers as shown in Table 6 with an average production cost of N28, 284:00k as shown in Table 2. Test piece mounted on the machine is presented on Figure 1.

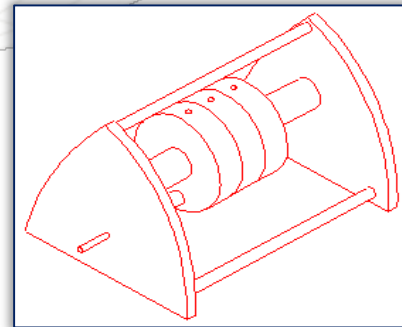

Figure 1: Test piece mounted on the machine

Table 1: Materials Specifications

S/N	Quantities	Part	Materials	Size
1	2	Frame	Polished teak wood	180mm radii quadrant.
2	3	Frame bolts	Mild steel	410mm by 200mm length
3	1	Specimen holder	Mild steel	
4	1	Testing disc	Aluminum	Ø95mm by 25mm thickness
5	1	Testing disc	Brass	Ø95mm by 25mm
6	1	Testing disc	Chromed mild steel	Ø95mm by 25mm thickness
7	1	Testing disc	Cast iron	Ø95mm by 25mm thickness
8	2	Disc stoppers	Mild steel	
9	12	Frame nut	Chromed mild steel	
10	2	Fused plug holder	Mild steel	Ø12mm by 20mm.
12	1	Mains cable	Nigeria wire and cable sheathed wire	1.5mm ² twin flex, (2 core flex).
13	2	Mains fuse	Ceramic	Ø15mm by 40mm length
14	1	Industrial rod heater		300mm length
15	4	Testing thermometer	Mercury in glass	110 °C (mmhg)
16	3	Insulator		6mm





Table 2: Bill of Engineering Measurements and Evaluations, (BEME)

S/N	Description	Quantity	Unit cost	Total cost
S/N	Descriptions	Unit	Cost/Unit(₦)	Cost (₦)
1	Frame	2	750	1500
2	Frame bolts	3	250	750
3	Specimen holder	1	900	900
4	Testing disc	4	300	12000
5	Disc stoppers	6	250	1500
6	Frame nut	12	50	600
7	Mains cable	2	50	100
8	Mains fuse plug	1	120	120
9	Industrial rod heater	1	2000	2000
10	Testing thermometer	4	800	3200
11	Insulator	7	60	540
12	Washers	12	30	360
	Subtotal(material cost)			23570
	Contingency (10%)	-	-	2357
	Overhead (10%)			2357
	TOTAL			28284

Experimental testing

The red heater gained heat and consequently transferred it to the discs (Aluminum, brass, mild steel and cast iron). The discs were heated and their rates of heat absorption were indicated by the thermometers. The results at varying time interval for the four different specimens: iron, brass, mild steel and aluminum were shown in Figures 2 & 3.

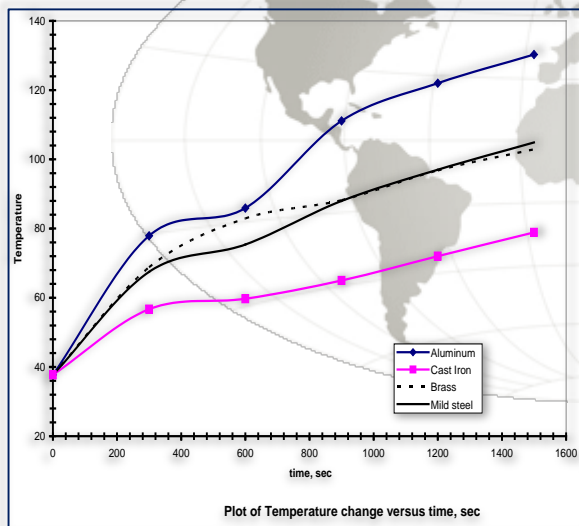

Figure 2: Experimental results of temperature change of each specimen in °C

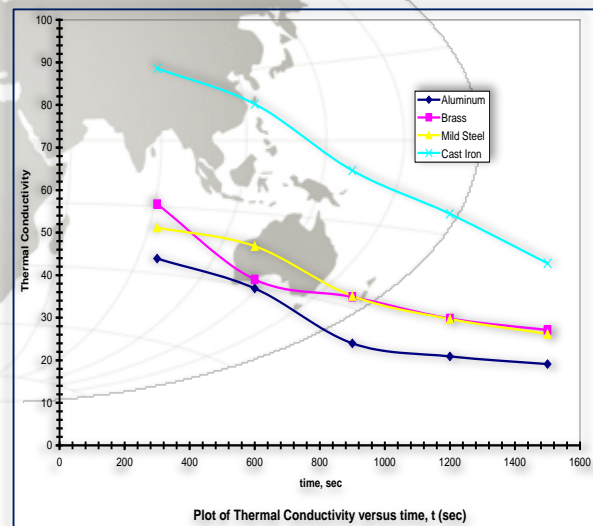

Figure 3: Theoretical results of calculated thermal conductivities

Theoretical Approach

Thermal conductivity (k) can be defined mathematically as (Karawacki & Gustavson, 1994).

$$K = K = \frac{QL}{A(T_2 - T_1)} \quad (6)$$

where: k is thermal conductivity, L is the length of material/apparatus, ΔT is the change in temperature and Q is the amount of heat flowing across the cross sectional area, Q = Quantity of electrical energy delivered per second, V = voltage per second, I = Current Delivered, L = Length of Specimen, T_2 = Temperature at hot point or final temperature, T_1 = Temperature at cold point or initial temperature and A = cross sectional area of the specimen

For an industrial rod heater, quantity of electrical energy delivered per second is given as 500 watt, (Srivastava, 1990). Cross sectional area A of each specimen can be calculated using equation (1), where radius of rod specimen is 0.0475 m, thus A is $7.088 \times 10^{-3} \text{ m}^2$.

$$Q = VI \quad (7)$$

The eqs. 5 through 7 were used with the temperature measurements carried out at time interval of 300 seconds to record thermal conductivities reading for each material and the results were presented in Table 3.





Development of Predictive Model

Regression analyses were performed using SAS package to develop the regression models representing the interactions between the thermal conductivity, K and time, t , for the four selected materials because there is dearth of information on mathematical determination of thermal conductivity. The results obtained were validated using Analysis of Variances (ANOVA) and statistical t-test

3. RESULTS AND DISCUSSIONS

Findings and Discussions

The observed temperature curves in °C for aluminum, brass, mild steel and cast iron are depicted in Figure 2. It indicates that aluminum conducts heat readily and also loses heat readily, cast iron is slow to conduct heat by absorbs and retains the heat with little heat loss, brass readily conducts, absorbs and then losses slowly and so does mild steel. Eqs. 1-3 were used to calculate thermal conductivities, K ($Wm^{-1} K^{-1}$) for different measured temperatures at 300 seconds interval, and Length = 25mm as shown in Figure 2.

From the Figure 2 and 3: it was deduced that the aluminum disc has the highest rate of absorption and conduction of heat followed by mild steel, then brass and finally cast iron. Although, the brass disc absorbed and conducted heat faster and earlier stage and at minimum time but as the heating process continued, the rate of absorption and conduction of heat of the mild steel disc overshoot that of the brass disc.

ANOVA analysis for temperature distribution in different materials in Table 3 shows analytical comparison of heat conduction and losses in terms of temperature rate in different materials. It shows that materials conduct heat and losses heat at different rate. In Table 3, $F_{cal} = 31.506$ is greater than $F_{critical} = 2.901$ which implies, that there is a significant difference in heat conduction and loses with time.

Table 3: ANOVA: Two-factor without replication for temperature distribution

Source of Variation	SS	Df	MS	F	P-value	F crit
Time	11528.98	5	2305.795	31.50583158	1.91E-07	2.901295204
Materials	3176.288	3	1058.763	14.46667694	0.000107	3.28738281
Error	1097.795	15	73.18631			
Total	15803.06	23				

ANOVA analysis in Table 4 shows analytical comparison of thermal conductivity and time in different materials. It shows that different materials resist heat at different rate. In Table 4, column represents different materials with $F_{cal} = 14.467$ is greater than $F_{critical} = 3.287$, there is significant difference in the rate of heat conduction and heat losses in different materials.

Table 4: ANOVA: Two-factor without replication for thermal conductivities

Source of Variation	SS	Df	MS	F	P-value	F crit
Time	11507.27	5	2301.454	31.1315429	2.07E-07	2.901295204
Thermal conduct	3146.08	3	1048.693	14.18557074	0.000119	3.28738281
Error	1108.902	15	73.92677			
Total	15762.25	23				

Determination Trendline Equation

Mathematical equation was established as a model to represent the interactions between the thermal conductivity, k with respect to duration, t as shown in Table 5. In each model equation in Table 5, represents time, in seconds and k represents thermal conductivity ($Wm^{-1} K^{-1}$). Substituting the values of x into each model equation will give the corresponding values of y which is the rate at which each material conducts heat. Increase in time t (secs) will give the decrease in thermal conductivity. For aluminum, a decrease in time t (secs) yields an explainable decrease in thermal conductivity by 90.97%. For cast iron, a decrease in time t (secs) yields an explainable increase in thermal conductivity by 99.36%. For brass, a decrease in time t (secs) yields an explainable decrease in thermal conductivity of brass by 85.83% which is explainable. For mild steel, a decrease in time t (secs) yields an explainable decrease in thermal conductivity by 96.20%. It implies that as time pass the function-ability of the materials reduce.

Table 5: Summary of developed models for predicting thermal conductivity with corresponding R^2

S/N	Material	Model	R^2
1	Aluminum	$K = -0.0219 t + 48.64$	0.9097
2	Cast iron	$K = -0.0391 t + 101.34$	0.9936
3	Brass	$K = -0.0228 t + 58.02$	0.8583
4	Mild steel	$K = -0.0224 t + 57.93$	0.962





Graphical Comparisons of Experimental and Modelled Thermal Conductivity results

It can be deduced from Figures 4 – 7 that, there is negligible difference between experimental and simulated thermal conductivity results of Aluminum, Cast Iron, Brass and Mild Steel. It can also be observed that the thermal conductivity decreases as the period increases. The models are further investigated by using statistical test known as t-test.

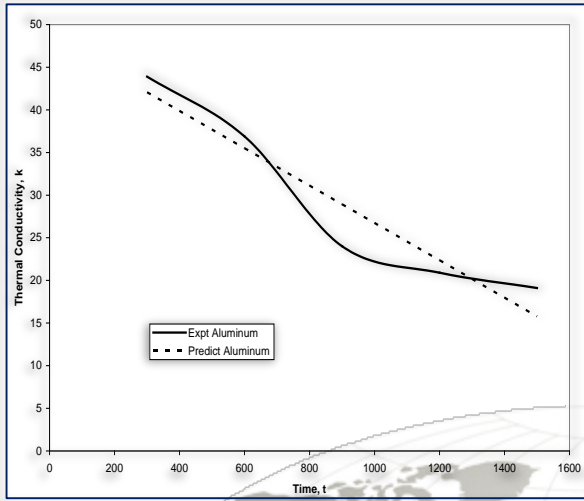

Figure 4: Graphical comparison of experimental and simulated Thermal Conductivity results of Aluminum

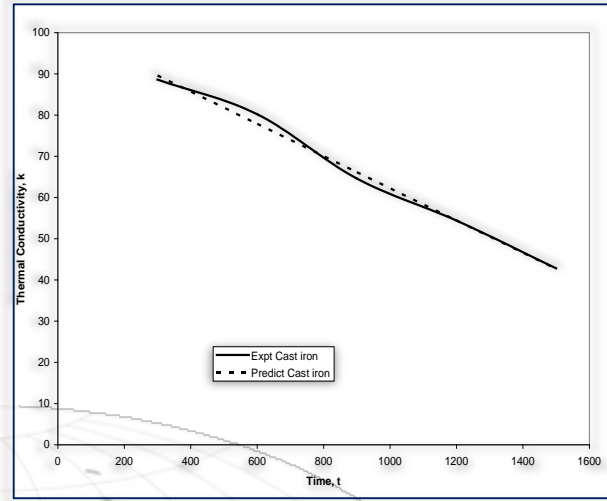

Figure 5: Graphical comparison of experimental and simulated Thermal Conductivity results of Cast Iron

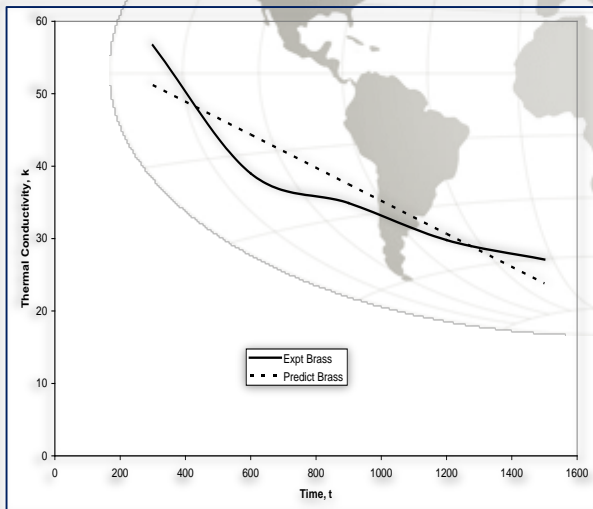

Figure 6: Graphical comparison of experimental and simulated Thermal Conductivity results of Brass

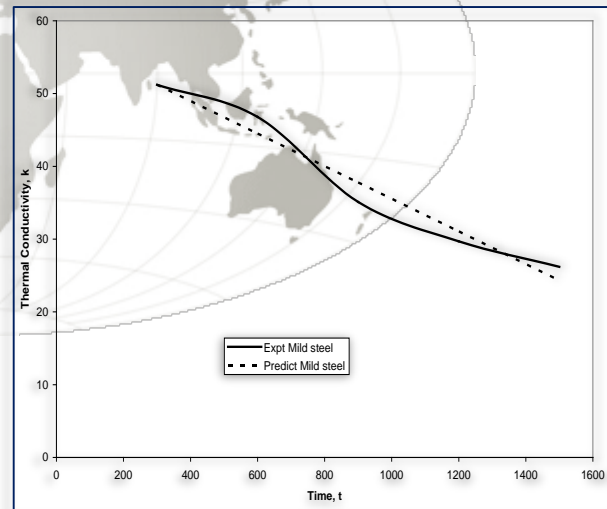

Figure 7: Graphical comparison of experimental and simulated Thermal Conductivity results of Mild Steel

T-Test

Table 6 presents summary of t-test analysis. Table 6 revealed that there is no significant difference between the models' results and experimental results for the four materials because t-stat values are less than t-critical values at 95% confidence limit, and 8 degree of freedom for both $P(T \leq t)$ one-tail = 0.499013 and $P(T \leq t)$ two-tail = 0.998026001. Hence the developed models for predicting thermal conductivity in the four materials are reliable.

Table 6: Summary of t-test: two-sample assuming unequal variances

Materials	t-stat	t-critical one tail	t-critical two tail
Aluminium	0.004460551	1.85954832	2.306005626
Brass	0	1.85954832	2.306005626
Mild Steel	0.004424211	1.85954832	2.306005626
Cast Iron	-0.002552375	1.85954832	2.306005626

4. CONCLUSIONS

A device for determining thermal conductivity of four different metals was constructed. The device measures the thermal conductivities of different metals and alloy. Experimental studies were carried out on four materials (cast iron, brass, mild steel and aluminum) to determine their respective thermal





conductivities at 300 seconds interval. Predictive models were developed for the materials to determine thermal conductivity at given time. Analysis of variance, ANOVA at 95% confidence limit confirmed that, there is significant difference between the thermal conductivities of the four selected material and statistical t-test analysis at 95% confidence limit confirmed that there is no significant difference between the models' results and experimental results. Finally, the predictive models save time, cost, enhance easy maintenance, reliability and accuracy of results.

References

- [1] Ajimotokun, H. A. and Ogunsola, A. D. (2009): Design and construction of a device for Thermal conductivity measurement. Technical Report No. 2009-01 University of Ilorin, Nigeria.
- [2] Callender, J.P. (1987): "Methods of measuring thermal conductivity of material", Mcgraw hill, New York.
- [3] David, R.L. (2008): "CRC handbook of Chemistry and Physics", 8th Edition, CRC Press/Taylor and Francis, Boca Raton, FL, USA.
- [4] Karawacki, E., and Gustavson, M., (1994): "Hot Disc Sensor", Review of Scientific Instruments, Vol. 8, 83.
- [5] Meadan, C.T. (1990): "Thermal conductivity of Material", Southampton Technical College Press, Southampton, UK.
- [6] Ogunsola, A.D (2007): "A Device for Thermal Conductivity Measurement in a Developing Economy", Scientific Research and Essay Vol. 2 No. 4, 1222-126.
- [7] Rajput, R.K. (2006): "Heat and Mass Transfer", Third Revised Ed., S. Chand & Company Ltd., Indian.
- [8] Srivastava G.P. (1990): "The Physics of Phonons", IOP Publishing Ltd, Bristol, London.

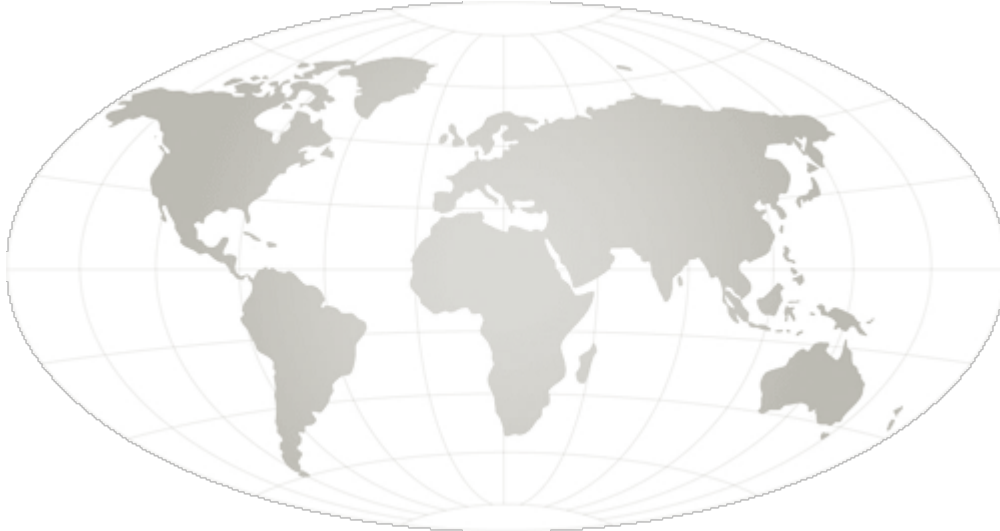

ANNALS of Faculty Engineering Hunedoara
– International Journal of Engineering



copyright © UNIVERSITY POLITEHNICA TIMISOARA,
FACULTY OF ENGINEERING HUNEDOARA,
5, REVOLUTIEI, 331128, HUNEDOARA, ROMANIA
<http://annals.fih.upt.ro>

